

**AGREEMENT TO PROVIDE THE PURCHASE OF A CLASS 5 TRUCK WITH
SERVICE BODY FOR THE LARAMIE COUNTY PUBLIC WORKS DEPARTMENT**
between
**LARAMIE COUNTY, WYOMING and KOIS BROTHERS EQUIPMENT COMPANY
INC.**

This Agreement is made and entered into by and between Laramie County, Wyoming, 310 W. 19th Street, Suite 300, Cheyenne, Wyoming, 82003 ("COUNTY") and Kois Brothers Equipment Company Inc., 5200 Colorado Blvd, Commerce City, CO 80022 ("CONTRACTOR").

I. PURPOSE

The CONTRACTOR is to provide the purchase of a Ford F550 4x4 Super cab with a Stellar crane body as requested in the RFB issued by the Laramie County Public Works Department.

II. TERM

This Agreement shall commence on the date last executed by the duly authorized representatives of the parties to this Agreement and shall remain in force until the project is completed by CONTRACTOR and accepted by COUNTY as set forth in the Agreement.

III. PAYMENT

COUNTY shall pay CONTRACTOR for services upon receipt of the CONTRACTOR'S invoice to the COUNTY as detailed in the RFB attached hereto as Exhibit A, which is fully incorporated herein. The total payment to CONTRACTOR under this Agreement shall not exceed \$158,398.00 (bid amount), unless negotiated by both parties in writing. Payment will be made to CONTRACTOR for materials upon invoice. No payment shall be made before the last signature is affixed to this Agreement. Payments shall be in accordance with Wyo. Stat. § 16-6-602 (as amended).

IV. RESPONSIBILITIES OF CONTRACTOR

- A. CONTRACTOR shall provide Class 5 Truck with a service body as specified in the bid attached hereto as Exhibit B.
- B. CONTRACTOR shall work closely with COUNTY in coordinating the purchase and delivery, CONTRACTOR will work with COUNTY as needed in accordance with such individuals or carriers as deemed appropriate by COUNTY.
- C. CONTRACTOR agrees to retain all required records for three (3) years after the County makes final payment and all other matters relating to the Agreement are concluded. CONTRACTOR agrees to permit access by the COUNTY or any of its duly authorized representatives to any books, documents, papers, and records

of the CONTRACTOR, which are directly pertinent to this specific Agreement for purposes including but not limited to audit, examination, excerpts, and transcriptions.

V. GENERAL PROVISIONS

A. Termination: This Agreement may be terminated (a) by either party at any time for failure of the other party to comply with the terms and conditions of this agreement; (b) by either party, with thirty (30) days' prior written notice to the other party; or (c) upon mutual written agreement by both parties.

B. Entire Agreement: This Agreement (5 pages), and the attached RFB (14 pages) and the attached Proposal (35 pages) represent the entire and integrated agreement and understanding between the parties and supersede all prior negotiations, statements, representations and agreements, whether written or oral.

C. Assignment: Neither this Agreement, nor any rights or obligations hereunder shall be assigned or delegated by a party without the prior written consent of the other party.

D. Modification: This Agreement shall be modified only by a written agreement, duly executed by all parties hereto.

E. Invalidity: If any provision of this Agreement is held invalid or unenforceable by any court of competent jurisdiction, or if the COUNTY is advised of any such actual or potential invalidity or unenforceability, such holding or advice shall not invalidate or render unenforceable any other provision hereof. It is the express intent of the parties that the provisions of this Agreement are fully severable.

F. Applicable Law and Venue: The parties mutually understand and agree this Agreement shall be governed by and interpreted pursuant to the laws of the State of Wyoming. If any dispute arises between the parties from or concerning this Agreement or the subject matter hereof, any suit or proceeding at law or in equity shall be brought in the District Court of the State of Wyoming, First Judicial District, sitting at Cheyenne, Wyoming. The foregoing provisions of this paragraph are agreed by the parties to be a material inducement to CONTRACTOR and to COUNTY in executing this Agreement. This provision is not intended nor shall it be construed to waive COUNTY's governmental immunity as provided in this Agreement.

G. Contingencies: CONTRACTOR certifies and warrants no gratuities, kickbacks or contingency fees were paid in connection with this Agreement, nor were any fees, commissions, gifts or other considerations made contingent upon the award of this Agreement.

H. Discrimination: All parties agree they will not discriminate against any person who performs work under the terms and conditions of this Agreement because of race, color, gender, creed, handicapping condition, or national origin.

I. ADA Compliance: All parties agree they will not discriminate against a qualified individual with disability, pursuant to law as set forth in the Americans with Disabilities Act, P.L. 101-336, 42 U.S.C. § 12101, *et seq.*, and/or any properly promulgated rules and regulations relating thereto.

J. Governmental/Sovereign Immunity: COUNTY does not waive its Governmental/Sovereign Immunity, as provided by any applicable law including W.S. § 1-39-101 *et seq.*, by entering into this Agreement. Further, COUNTY fully retains all immunities and defenses provided by law with regard to any action, whether in tort, contract or any other theory of law, based on this Agreement.

K. Indemnification: To the fullest extent permitted by law, CONTRACTOR agrees to indemnify and hold harmless COUNTY, its elected and appointed officials, employees and volunteers from any and all liability for injuries, damages, claims, penalties, actions, demands or expenses arising from or in connection with work performed by or on behalf of CONTRACTOR for COUNTY except to the extent liability is caused by the sole negligence or willful misconduct of COUNTY or its employees. CONTRACTOR shall carry liability insurance sufficient to cover its obligations under this provision and provide COUNTY with proof of such insurance.

L. Third Parties: The parties do not intend to create in any other individual or entity the status of third-party beneficiary, and this Agreement shall not be construed so as to create such status. The rights, duties and obligations contained in this Agreement shall operate only between the parties to the Agreement and shall inure solely to the benefit of the parties to this Agreement.

M. Conflict of Interest: COUNTY and CONTRACTOR affirm, to their knowledge, no CONTRACTOR employee has any personal beneficial interest whatsoever in the agreement described herein. No staff member of CONTRACTOR, compensated either partially or wholly with funds from this Agreement, shall engage in any conduct or activity which would constitute a conflict of interest relative to this Agreement.

N. Force Majeure: Neither party shall be liable to perform under this Agreement if such failure arises out of causes beyond control, and without the fault or the negligence of said party. Such causes may include, but are not restricted to, Act of God or the public enemy, fires, floods, epidemics, quarantine restrictions, freight embargoes, and unusually severe weather. In every case, however, a failure to perform must be beyond the control and without the fault or the negligence of said party.

O. Limitation on Payment: COUNTY's payment obligation is conditioned upon the availability of funds, which are appropriated or allocated for the payment of this obligation. If funds are not allocated and available for the continuance of the services and equipment provided by CONTRACTOR the Agreement may be terminated by COUNTY at the end of the period for which funds are available. COUNTY shall notify CONTRACTOR at the earliest possible time of the services, which will or may be affected by a shortage of funds. At the earliest possible time means at least thirty (30) days before the shortage will affect payment of claims, if COUNTY knows of the shortage at least thirty (30) days in advance. No penalty shall accrue to

COUNTY in the event this provision is exercised, and COUNTY shall not be obligated or liable for any future payments due or for any damages as a result of termination under this provision. This provision shall not be interpreted or construed to permit COUNTY to terminate this Agreement in order to acquire similar services from another party.

P. Notices: All notices required and permitted under this Agreement shall be deemed to have been given, if and when deposited in the U.S. Mail, properly stamped and addressed to the party for whom intended at such parties' address listed herein, or when personally delivered personally to such party. A party may change its address for notice hereunder by giving written notice to the other party.

Q. Compliance with Law: CONTRACTOR shall comply with all applicable laws, regulations and ordinances, whether Federal, State or Local.

[The remainder of this page is intentionally left blank.]

**AGREEMENT TO PROVIDE THE PURCHASE OF A CLASS 5 TRUCK WITH
SERVICE BODY FOR THE LARAMIE COUNTY PUBLIC WORKS DEPARTMENT**
between
**LARAMIE COUNTY, WYOMING and KOIS BROTHERS EQUIPMENT COMPANY
INC.**

Signature Page

LARAMIE COUNTY, WYOMING

By: _____ Date _____
Chairman, Laramie County Commissioners

ATTEST:

By: _____ Date _____
Debra Lee, Laramie County Clerk

CONTRACTOR: KOIS BROTHERS EQUIPMENT COMPANY

By:  _____ Date 2/8/2024
Name: Jesse McKinley
Title: Territory Sales

This Agreement is effective the date of the last signature affixed to this page.

REVIEWED AND APPROVED AS TO FORM ONLY:

By:  _____ Date 2-8-24
Laramie County Attorney's Office

REQUEST FOR BIDS
Laramie County Public Works
One (1) new Class 5 Truck with Service Body
Closing Date: January 4, 2024

Purpose of Request for Bids (RFB)

Laramie County is soliciting competitive bids for qualified vendors who can provide one (1) new Class 5 Truck with Service Body for Laramie County Public Works. This project is being funded with Federal ARPA funds (ALN # 21.027) and selected vendor will be required to be registered in sam.gov.

Table of Contents

| | | |
|------------|----------------------------------------------|-----------|
| 1.0 | PURPOSE & OVERVIEW | 2 |
| 2.0 | SCOPE OF SERVICES | 2 |
| 3.0 | GENERAL TERMS & CONDITIONS | 5 |
| 3.1 | RFB CLOSING DATE | 5 |
| 3.2 | DELIVERY OF BIDS | 5 |
| 3.3 | PRE-BID INFORMATION | 6 |
| 3.4 | PUBLIC RFB OPENING | 6 |
| 3.5 | BID FORM | 6 |
| 3.6 | QUESTIONS CONCERNING RFB | 6 |
| 3.7 | CLARIFICATION AND ADDENDA | 6 |
| 3.8 | AWARD | 7 |
| 3.9 | CONTRACT | 7 |
| 3.10 | DISCLOSURE OF RFB CONTENT | 7 |
| 3.11 | RESPONDENT'S RESPONSIBILITY | 8 |
| 3.12 | PAYMENT TERMS | 8 |
| 3.13 | MINOR IRREGULARITIES | 8 |
| 3.14 | DEVIATIONS | 8 |
| 3.15 | SELECTION CRITERIA | 9 |
| 3.16 | TERMINATION / CANCELLATION OF CONTRACT | 9 |
| 3.17 | INCURRED EXPENSES | 9 |
| 3.18 | PRESENTATIONS BY RESPONDENTS | 9 |
| 3.19 | MINIMUM SPECIFICATIONS | 10 |
| 3.20 | RESPONDENT'S PERSONNEL | 10 |
| 3.21 | BID ACCEPTANCE/REJECTION | 10 |
| 4.0 | 4.0 SUBMITTAL REQUIREMENTS | 10 |
| 5.0 | 5.0 DISCLOSURES | 11 |
| 6.0 | BID FORM | 14 |

1.0 Purpose & Overview

Laramie County Public Works is soliciting competitive, sealed bids from qualified vendors to provide one (1) new Class 5 Truck with Service Body.

2.0 Scope of Services

Specifications for Bid

The winning bidder must be registered with sam.gov

Estimated date of delivery: _____

General

- Extended cab truck chassis (Cab color must be white) (8-foot bed/chassis length min)
 - Meets specifications: Yes No
- Gasoline/Diesel powered engine (Describe engine under bid proposal)

Bid proposal _____

- Class 5 Chassis (GVWR between 16,000 and 19,500)
 - Meets specifications: Yes No
- Four-wheel drive
 - Meets specifications: Yes No
- Dual rear wheels
 - Meets specifications: Yes No
- Automatic transmission
 - Meets specifications: Yes No
- Locking rear axle
 - Meets specifications: Yes No
- 250 Amp alternator
 - Meets specifications: Yes No
- Engine block heater
 - Meets specifications: Yes No
- Cruise control
 - Meets specifications: Yes No

- Rear vision camera
 - Meets specifications: Yes No
- Uplifter switches
 - Meets specifications: Yes No
- Air conditioning
 - Meets specifications: Yes No
- AM/FM radio (Bluetooth)
 - Meets specifications: Yes No
- Rubber floor mats
 - Meets specifications: Yes No

Service Body Specs

- 6,000-pound hydraulic service crane (20–26-foot reach)
 - Meets specifications: Yes No
- Wireless crane controls
 - Meets specifications: Yes No
- Hydraulic out riggers
 - Meets specifications: Yes No
- Drawer sections in all driver's side cabinets
 - Meets specifications: Yes No
- Front torch storage cabinet (vented and reinforced)
 - Meets specifications: Yes No
- Tool storage rear bumper (with vice mounted on it)
 - Meets specifications: Yes No
- Tie downs in bed
 - Meets specifications: Yes No
- Aluminum doors (with weather stripping and locking handles)
 - Meets specifications: Yes No
- Cabinet lighting
 - Meets specifications: Yes No
- LED flood lights (x6)
 - Meets specifications: Yes No

- 360-Degree beacon LED warning strobes – Amber (low profile)
 - Meets specifications: Yes No
- Adjustable cabinet shelving (for passenger side cabinets)
 - Meets specifications: Yes No
- Tailgate
 - Meets specifications: Yes No
- Reinforced welder mount (for Miller Bobcat 250)
 - Meets specifications: Yes No
- 3,500-watt inverter (with 120-volt outlet wired into bed)
 - Meets specifications: Yes No
- Rhino lined bed and tailgate
 - Meets specifications: Yes No

Safety & Other

- Paper copies of Service, Repair, and Parts Manuals (to be supplied upon delivery)
 - Meets specifications: Yes No
- One complete set of filters shall be provided
 - Meets specifications: Yes No

Warranty and Training

TRAINING AND DIAGNOSTICS:

With delivery of the vehicle, a qualified representative shall instruct County Operators and Mechanics in the proper operation, servicing, lubrication, adjustments, and preventative maintenance of the equipment, including the crane.

Vendor will provide, in letter form only, type of warranty supplied on quoted equipment. The letter shall include type of service provided, guarantee of parts, and cost of service during warranty period. Vendor may also provide any other material which they feels gives their equipment an advantage on service and warranty. Please state any extended warranties and their associated cost in the warranty period.

The ability of bidder to provide superior warranty and service may be used to determine successful bidder.

Printed specifications on machine bid shall be presented. All above specifications filled in must be legible. With delivery of equipment and components, Manufacturer’s Statement of Origin shall be supplied.

Additional Notes:

- A. The respondent shall provide the following information for each proposed system:
 - 1. A complete bid including all related costs for providing the equipment, supplies and installation as outlined above.
 - 2. Delivery of all equipment, supplies, and installation.
 - 3. Enter into a written contract for work with Laramie County.
 - 4. Contractor shall comply with all applicable Federal and State statutes and regulations as well as local ordinances.

- B. The person or persons provided by the respondent to complete work shall be fully qualified to provide said services.

- C. All work provided by the respondent shall be in conformance with local, state, and Federal rules and regulations.

- D. All equipment shall be responsive to the needs of the County, shall be performed in accordance with County programs, policies, and procedures, and shall utilize appropriate methods and techniques.

- E. All records, including digital information, video tapes and audio tapes, related to the contract services performed for the County shall be subject to the Wyoming Public Records Laws and shall be maintained and made available in accordance with those laws and public records policies and procedures of the County. Records shall be made available to the County without question upon request of the County, in accordance with the requirements of law. Citizen requests for such records shall be processed through the County. All records, including all types of electronic records, related to the contract and services performed there under shall be the property of the County at the end of the contract, or at the end of the County's fiscal year, or upon demand of the County, whichever occurs first. The County shall specify the minimum records to be maintained by the respondent. The respondent may maintain additional records at its discretion.

3.0 General Terms & Conditions

3.1 RFB Closing Date

Bids must be received by the Laramie County Public Works Department (LCPW) at 13797 Prairie Center Circle, Cheyenne, Wyoming 82009 no later than **2:00 PM, MST, on January 4, 2024**. Bids received after this time will not be considered. Please note for bid delivery purposes, the hours of operation for LCPW are Monday through Thursday, 6:00 AM to 4:30 PM, MST.

3.2 Delivery of Bids

All bids shall be sealed and delivered or mailed to the address of Laramie County Public Works (faxes and emails will not be accepted).

3.3 Optional Pre-bid Information

No specific pre-bid meeting will be held. Each respondent shall contact John Poelma 307-633-4690 or john.poelma@laramiecountywy.gov to discuss the bid with the County, if needed.

3.4 Public RFB Opening

Only the names of the vendors submitting bids will be read aloud at the RFB opening. The bids will be available for inspection during normal business hours in the Laramie County Public Works Department within three (3) working days of the closing date, by appointment. Bid opening will occur on **January 4, 2024, at 2:15 PM** at the Laramie County Public Works office. A complete tabulation of bids will be available after it is completed.

Individuals covered by the Americans with Disabilities Act of 1990 in need of accommodations to attend public RFB openings or meetings should contact the Public Works Department in Cheyenne at (307) 633-4690 at least five (5) days prior to the date.

3.5 Bid Form

- A. See Submittal Requirements for complete details.
- B. Each respondent shall submit THREE (3) complete sets of the bid form, one marked "ORIGINAL" and TWO (2) marked "COPY". The bid shall be submitted on an exact copy of the attached bid form.
- C. The bid form must be signed by an official authorized to legally bind the respondent to all RFB provisions contained herein.
- D. Terms and conditions differing from those in this RFB may be cause for disqualification of the bid.

3.6 Questions Concerning RFB

Questions concerning any portion of this RFB should be directed in writing to John Poelma, Public Works Department, named below, who shall be the official point of contact for this RFB. Mark cover page or envelope(s) "**Class 5 truck with Service Body**".

Submit questions to:

John Poelma
Deputy Director
Public Works
(307) 633-4302

John.Poelma@laramiecountywy.gov

3.7 Clarification and Addenda

It is incumbent upon each respondent to carefully examine all specifications, terms, and conditions contained herein. Any inquiries, suggestions, or requests concerning interpretation, clarification or additional information shall be made in writing, (facsimile transmissions

acceptable) through the Assistant Director named above. The County will not be responsible for any oral representation(s) given by any employee, representative or others. The issuance of a written addendum is the only official method by which interpretation, clarification or additional information can be given.

If it becomes necessary to revise or amend any part of this RFB, notice may be obtained by accessing the Laramie County web site. Respondents in their bid must acknowledge receipts of amendments. **Each respondent should ensure that they have received all addenda and amendments to this RFB before submitting their bid. Please check the Laramie County web site at <http://www.laramiecountywy.gov> for any addenda.**

3.8 Award

The County reserves the right to award the contract to the respondent(s) that the County deems to offer the best overall bid(s). The County is therefore not bound to accept a bid on the basis of lowest price. In addition, the County at its sole discretion, reserves the right to cancel this RFB, to modify the quantities of product we purchase, to reject any and all bids, to waive any and all informalities and/or irregularities, or to re-advertise with either the identical or revised specifications, if it is deemed to be in the best interest of the County to do so. The County also reserves the right to make multiple awards, based on experience and qualifications if it is deemed to be in the County's best interest.

3.9 Contract

The contents of this RFB and all provisions of the successful bid deemed pertinent by the County may be incorporated into a contract and become legally binding. A separate contract document will be issued.

The County Commissioners are the sole Contracting Officer for Laramie County, Wyoming, and only he/she or his/her designee is authorized to make changes to any contract. The County shall be responsible for only those orders placed by the County on an authorized signed Purchase Order or Price Agreement. The County shall not be responsible for any order, change, substitution or any other discrepancy from the Purchase Order or Price Agreement. If there is any question about the authenticity of a Purchase Order, Price Agreement or change order, the respondent should promptly contact the Public Works Department at (307) 633-4690.

3.10 Disclosure of RFB Content

All material submitted becomes the property of the County and may be returned only at the County's option. The County has the right to use any or all ideas presented in any reply to this RFB. Selection or rejection of any bid does not affect this right.

3.11 Respondent's Responsibility

A respondent, by submitting a bid represents that:

- A. The respondent has read and understands the RFB in its entirety that and the bid is made in accordance therewith, and
- B. The respondent possesses the capabilities, resources, and personnel necessary to provide efficient and successful service to the County, and;
- C. Before submitting a bid, each respondent shall make all investigations and examinations necessary to ascertain site and/or local conditions and requirements affecting the full performance of the contract and to verify any representations made by Laramie County upon which the respondent will rely. If the respondent receives an award because of its bid submission, failure to have made such investigations and examinations will in no way relieve the respondent from its obligations to comply in every detail with all provisions and requirements of the contract, nor will a plea of ignorance of such conditions and requirements be accepted as a basis for any claim by the respondent for additional compensation or relief.

3.12 Payment Terms

The County will remit full payment on all undisputed invoices within forty-five (45) days from receipt by the appropriate person(s) (to be designated at time of contract) of the invoice(s) or receipt of all products or services ordered.

3.13 Minor Irregularities

The County reserves the right to waive minor irregularities in bids, providing such action is in the best interest of the County. Minor irregularities are defined as those that have no adverse effect on the County's best interests and will not affect the outcome of the selection process by giving the respondent an advantage or benefit not enjoyed by other respondents.

3.14 Deviations

All bids must clearly and with specific detail, note all deviations to the exact requirements imposed upon the respondent by the General Terms & Conditions. Such deviations must be stated upon the Bid Form; otherwise, Laramie County will consider the subject bids as being made in strict compliance with said General Terms & Conditions to respondents; the respondent being held therefore accountable and responsible. Respondents are hereby advised that Laramie County will only consider bids that meet the exact requirements imposed by the General Terms & Conditions; except, however, said bids may not be subject to such rejection where, at the sole discretion of Laramie County, the stated deviation is considered to be equal or better than the imposed requirement and where said deviation does not destroy the competitive character of the RFB process by affecting the amount of the bid such that an advantage or benefit is gained to the detriment of the other respondents.

3.15 Selection Criteria

Each bid shall be evaluated using the following criteria:

1. Proper submittal of ALL documentation as required by this bid
2. Overall scope and quality of the proposed project
3. Meeting or exceeding the requirements of the RFB
4. Quality and compatibility of the work proposed
5. Ability to accomplish project in a timely manner
6. The benefits to Laramie County as it pertains to:
 - a. Related experience in the areas covered in the RFB
 - b. Past record of performance on contracts with government agencies and private industry with respect to such factors as control of costs, quality of work and ability to meet schedules
 - c. Experience, ability, and overall quality of past and current projects

3.16 Termination / Cancellation of Contract

The County reserves the right to cancel the contract without cause with a minimum thirty (30) days written notice. Termination or cancellation of the contract will not relieve the respondent of any obligations for any deliverables entered into prior to the termination of the contract (i.e., reports, materials, statements of accounts, etc., required and not received). Termination or cancellation of the contract will not relieve the respondent of any obligations or liabilities resulting from any acts committed by the respondent prior to the termination of the contract.

3.17 Incurred Expenses

This RFB does not commit Laramie County to award a contract. Nor shall Laramie County be responsible for any cost or expense which may be incurred by the respondent in preparing and submitting the bid called for in this RFB, or any cost or expense incurred by the respondent prior to the execution of a contract agreement.

3.18 Presentations by Respondents

Laramie County, at its sole discretion, may ask individual respondents to make oral presentations and/or demonstrations without charge to the County.

The County reserves the right to require any respondent to demonstrate to the satisfaction of the County that the respondent has the fiscal and managerial abilities to properly furnish the services proposed and required to fulfill the contract. The demonstration must satisfy the County and the County shall be the sole judge of compliance.

Respondents are cautioned not to assume that presentations will be required and should include all pertinent and required information in their original bid package.

3.19 Minimum Specifications

The specifications listed in the Scope of Service are the minimum required performance specifications for this RFB. They are not intended to limit competition nor specify any particular respondent, but to ensure that the County receives quality services.

3.20 Respondent's Personnel

The respondent shall be responsible for ensuring that its employees, agents and subcontractors comply with all applicable laws and regulations and meet all federal, state and local requirements related to their employment and position. The respondent certifies that it does not and will not during the performance of the contract employ illegal alien workers or otherwise violate the provisions of the federal Immigration Reform and Control Act of 1986, as amended. During the performance of the contract, the respondent agrees to the following:

The respondent shall not discriminate against any employee or applicant for employment because of race, religion, color, sex, age, handicap or national origin, except when such condition is a bona fide occupational qualification reasonably necessary for the normal operations of the respondent.

The respondent agrees to post in conspicuous places, visible to employees and applicants for employment, notices setting forth the provisions of this nondiscrimination clause.

The respondent, in all solicitations or advertisements for employees placed by or on behalf of the respondent, shall state that such respondent is an Equal Opportunity Employer.

3.21 Bid Acceptance/Rejection

The County reserves the right to accept or reject any or all bids received as a result of this RFB, or to negotiate separately with competing respondents, and to waive any informalities, defects, or irregularities in any bid, or to accept that bid or bids, which in the judgment of the proper officials, is in the best interest of the County.

4.0 Submittal Requirements

Bids shall include all the information solicited in this RFB, and any additional data that the respondent deems pertinent to the understanding and evaluating of the bid. Bids shall be organized, and sections tabbed in the following order. The respondent should not withhold any information from the written response in anticipation of presenting the information orally or in a demonstration, since oral presentations or demonstrations may not be solicited. All bids shall include at minimum:

Tab 1 – Respondent’s Profile

A brief profile of the firm, including the firm’s overall qualifications to provide services necessary to fulfill all requirements outlined in the project Scope of Work.

Tab 2 - Completed Bid Form (use attached form)

Tab 3 – References

List at least three (3) recent references where the equivalent project(s) have been conducted within the past five years.

Tab 4 – Other Information

Include any additional information you believe will assist the County in the selection process of qualified respondents. Please be succinct.

5.0 Disclosures

The laws of Wyoming require that the contents of all bids shall be placed in the public domain and be open to inspection by interested parties. Trade secrets or proprietary information that are recognized as such and are protected by law may be withheld if clearly identified as such in the bid. The entire bid cannot be designated as proprietary or a trade secret. If a request is received to examine portions designated as proprietary or a trade secret, Laramie County will notify the vendor to permit the vendor to defend the proprietary nature of the information.

If a respondent discovers any ambiguity, conflict, discrepancy, exclusionary specifications, omission, or other error in this document, the respondent shall immediately notify the issuing office. If the respondent is awarded a contract, then such respondent will not be entitled to additional compensation, relief, or time by reason of the error or its later correction.

The successful respondent will be expected to enter into a contract with Laramie County upon terms acceptable to the County. Respondent will be required to be registered in Sam.gov to receive federal ARPA funding as a contractor/vendor to this RFB.

Following the award of the contract, responses to this bid are subject to release as public information unless specific parts of the response can be shown to be exempt from the laws of the State of Wyoming. Respondents are advised to consult with their legal counsel regarding disclosure issues and take the appropriate precautions to safeguard trade secrets or any other proprietary information. Laramie County assumes no obligation or responsibility for asserting legal arguments on behalf of potential respondents.

If a respondent believes that parts of a bid are confidential then the respondent must so specify. The respondent must mark in bold red letters the term “**CONFIDENTIAL**” on that part of the response, which the respondent believes to be confidential. The respondent must submit in

writing specific detailed reasons, including any relevant legal authority, stating why the respondent believes the material to be confidential. Vague and general claims as to confidentiality will not be accepted. Laramie County will be the sole judge as to whether a claim is general and/or vague in nature. All parts of bids, which are not marked as confidential, will be automatically considered public information after the contract is awarded. The successful bid may be considered public information even though parts are marked confidential.

Bids must be signed by a person authorized to commit the respondent to provide the services requested in this RFB. Submission of a signed bid will be interpreted to mean the respondent has agreed to all terms and conditions set forth in all of the sheets which make up this RFB.

Laramie County accepts no obligations for the costs incurred in responding to this RFB in anticipation of being awarded a contract. Laramie County reserves the right to reject any and all submitted bids. It is understood that all bids become the property of Laramie County and will be available for public inspection. No obligation is made by retention of these bids, nor is Laramie County committed to awarding a contract as a result of this RFB.

Each respondent must disclose any existing or potential conflict of interest relative to the performance of the requirements of this bid. Examples of potential conflicts may include an existing business or personal relationship between the respondent, its principal or any affiliate or subcontractor, with Laramie County or any other entity or person involved in any way in the project that is the subject of this RFB. Similarly, any personal or business relationship between the respondent, the principals, or an affiliate or subcontractor, with any employee of Laramie County or its suppliers must be disclosed. Any such relationship that might be perceived or represented as a conflict should be disclosed. Failure to disclose any such relationship or reveal personal relationships with Laramie County employees may be cause for contract termination. Laramie County will decide if an actual or perceived conflict should result in bid disqualification. By submitting a response to this RFB, all respondents affirm that they have not given, nor intend to give, any time hereafter any economic opportunity, future employment, gift, loan, gratuity, special discount, tip, favor, or service to a Laramie County employee or representative in connection with the procurement.

Governmental Immunity

Laramie County does not waive its Governmental/Sovereign Immunity, as provided by any applicable law including W.S. 1-39-101 et seq., by issuing this RFB or by entering into any subsequent agreement. Further, Laramie County fully retains all immunities and defenses provided by law with regard to any action, whether in tort, contract or any other theory of law, based on this RFB or any subsequent agreement.

Indemnification

To the fullest extent permitted by law, the successful respondent agrees to indemnify and hold harmless Laramie County, its appointed officials, elected officials, employees and volunteers from any and all liability for injuries, damages, claims, penalties, actions, demands or expenses

arising from or in connection with any work performed by or on behalf of respondent for Laramie County pursuant to any agreement with Laramie County.

Termination

The selection may be terminated (a) by either party at any time for failure of the other party to comply with the terms and conditions of the RFB or any subsequent agreement; (b) by either party, with thirty days' prior written notice to the other party; or (c) upon mutual written agreement by both parties.

Force Majeure

Neither the respondent nor Laramie County shall be liable to perform under this RFB or subsequent agreement if such failure arises out of causes beyond control, and without the fault or the negligence of said party. Such causes may include, but are not restricted to, Act of God or the public enemy, fires, floods, epidemics, quarantine restrictions, freight embargoes and unusually severe weather. In every case, however, a failure to perform must be beyond the control and without the fault or the negligence of said party.

The submission of a bid shall be considered acceptance to all the terms and conditions provided herein and in the various bid documents, unless specifically noted otherwise in the bid.

[REMAINDER OF PAGE LEFT INTENTIONALLY BLANK]

6.0 BID FORM (Attachment)

TO: John Poelma
13797 Prairie Center Circle
Cheyenne, WY 82009
(307) 633-4302

The undersigned hereby declares that *[firm name]* _____

_____ have carefully examined the specifications to furnish: **One (1) new Class 5 Truck with Service Body** for which bids were advertised to be received **no later than 2:00 PM, MST, January 4, 2024** and further declare that *[firm name]*

_____ will furnish the said work according to specifications.

Proposed Cost Total Estimated Cost for Project: \$ _____

The above prices are all inclusive; County shall pay no other forms of compensation. The County reserves the right to add additional related services that were not known at the time of the publishing of this RFB to any resulting contract, upon negotiations with awarded contractors that is mutually agreeable.

Have you supplied the Submittal Requirements outlined above? _____ YES _____ NO

Laramie County reserves the right to reject any or all bids, to waive informalities, and to accept all or any part of any bid as they may deem to be in the best interest of the County.

I hereby certify that I have read and understand the requirements of this Request for Bids and, that I as the respondent, will comply with all requirements, and that I am duly authorized to execute this bid/offer document and any contract(s) and/or other transactions required by award of this RFB.

Company _____

By _____ (Print name)

Signature _____

Address _____

City _____ State _____ ZIP _____

Telephone _____ Fax _____

E-Mail Address: _____

DUNS# _____

Bid Tabulation- Public Works Service Truck
Thursday January 4, 2024 at 2:15pm

| <u>Bidder</u> | <u>Sam.gov Registration</u> | <u>Experience</u> | <u>Meets Specifications</u> | <u>Schedule</u> | <u>Past Performance</u> | <u>Insurance and Bond</u> | <u>Bid Price</u> |
|-----------------------------|-----------------------------|-------------------|----------------------------------------------------------|-----------------|-------------------------|---------------------------|------------------|
| Kois Brothers Equipment | Yes, expires 1/10/24 | Yes | Yes-F550 4x4 Diesel Truck with Stellar body and crane | 11/1/2024 | Good | NA | \$158,398.00 |
| Fremont Motor Company | Yes, expires 2/1/24 | Yes | Yes, F550 4x4 Diesel Truck with Ameritech body and crane | 6-12 Months | Good | NA | \$162,184.01 |
| KGA Ken Garff Bid Option #1 | Yes, expires 6/6/24 | Yes | Yes, F550 4x4 Diesel Truck with Ameritech body and crane | 180-300 Days | Good | NA | \$157,809.00 |
| KGA Ken Garff Bid Option #2 | Yes, expires 6/6/24 | Yes | Yes, F550 4x4 Diesel Truck with Reading body and crane | 180-300 Days | Good | NA | \$167,018.00 |

Ko15

REQUEST FOR BIDS
Laramie County Public Works
One (1) new Class 5 Truck with Service Body
Closing Date: January 4, 2024

Purpose of Request for Bids (RFB)

Laramie County is soliciting competitive bids for qualified vendors who can provide one (1) new Class 5 Truck with Service Body for Laramie County Public Works. This project is being funded with Federal ARPA funds (ALN # 21.027) and selected vendor will be required to be registered in sam.gov.

Table of Contents

| | | |
|------|---------------------------------------------|----|
| 1.0 | PURPOSE & OVERVIEW | 2 |
| 2.0 | SCOPE OF SERVICES..... | 2 |
| 3.0 | GENERAL TERMS & CONDITIONS | 5 |
| 3.1 | RFB CLOSING DATE..... | 5 |
| 3.2 | DELIVERY OF BIDS..... | 5 |
| 3.3 | PRE-BID INFORMATION..... | 6 |
| 3.4 | PUBLIC RFB OPENING..... | 6 |
| 3.5 | BID FORM..... | 6 |
| 3.6 | QUESTIONS CONCERNING RFB..... | 6 |
| 3.7 | CLARIFICATION AND ADDENDA..... | 6 |
| 3.8 | AWARD..... | 7 |
| 3.9 | CONTRACT..... | 7 |
| 3.10 | DISCLOSURE OF RFB CONTENT..... | 7 |
| 3.11 | RESPONDENT'S RESPONSIBILITY..... | 8 |
| 3.12 | PAYMENT TERMS..... | 8 |
| 3.13 | MINOR IRREGULARITIES..... | 8 |
| 3.14 | DEVIATIONS..... | 8 |
| 3.15 | SELECTION CRITERIA..... | 9 |
| 3.16 | TERMINATION / CANCELLATION OF CONTRACT..... | 9 |
| 3.17 | INCURRED EXPENSES..... | 9 |
| 3.18 | PRESENTATIONS BY RESPONDENTS..... | 9 |
| 3.19 | MINIMUM SPECIFICATIONS..... | 10 |
| 3.20 | RESPONDENT'S PERSONNEL..... | 10 |
| 3.21 | BID ACCEPTANCE/REJECTION..... | 10 |
| 4.0 | 4.0 SUBMITTAL REQUIREMENTS | 10 |
| 5.0 | 5.0 DISCLOSURES | 11 |
| 6.0 | BID FORM | 14 |

1.0 Purpose & Overview

Laramie County Public Works is soliciting competitive, sealed bids from qualified vendors to provide one (1) new Class 5 Truck with Service Body.

2.0 Scope of Services

Specifications for Bid

The winning bidder must be registered with sam.gov

Estimated date of delivery: Before Nov 2024

General

- Extended cab truck chassis (Cab color must be white) (8-foot bed/chassis length min)
 - Meets specifications: Yes No

- Gasoline/Diesel powered engine (Describe engine under bid proposal)
Bid proposal Diesel 6.7L

- Class 5 Chassis (GVWR between 16,000 and 19,500)
 - Meets specifications: Yes No

- Four-wheel drive
 - Meets specifications: Yes No

- Dual rear wheels
 - Meets specifications: Yes No

- Automatic transmission
 - Meets specifications: Yes No

- Locking rear axle
 - Meets specifications: Yes No

- 250 Amp alternator
 - Meets specifications: Yes No

- Engine block heater
 - Meets specifications: Yes No

- Cruise control
 - Meets specifications: Yes No

- **Rear vision camera**
 - Meets specifications: Yes No
- **Uplifter switches**
 - Meets specifications: Yes No
- **Air conditioning**
 - Meets specifications: Yes No
- **AM/FM radio (Bluetooth)**
 - Meets specifications: Yes No
- **Rubber floor mats**
 - Meets specifications: Yes No

Service Body Specs

- **6,000-pound hydraulic service crane (20–26-foot reach)**
 - Meets specifications: Yes No
- **Wireless crane controls**
 - Meets specifications: Yes No
- **Hydraulic out riggers**
 - Meets specifications: Yes No
- **Drawer sections in all driver's side cabinets**
 - Meets specifications: Yes No
- **Front torch storage cabinet (vented and reinforced)**
 - Meets specifications: Yes No
- **Tool storage rear bumper (with vice mounted on it)**
 - Meets specifications: Yes No
- **Tie downs in bed**
 - Meets specifications: Yes No
- **Aluminum doors (with weather stripping and locking handles)**
 - Meets specifications: Yes No
- **Cabinet lighting**
 - Meets specifications: Yes No
- **LED flood lights (x6)**
 - Meets specifications: Yes No

- 360-Degree beacon LED warning strobes – Amber (low profile)
 - Meets specifications: Yes No
- Adjustable cabinet shelving (for passenger side cabinets)
 - Meets specifications: Yes No
- Tailgate
 - Meets specifications: Yes No
- Reinforced welder mount (for Miller Bobcat 250)
 - Meets specifications: Yes No
- 3,500-watt inverter (with 120-volt outlet wired into bed)
 - Meets specifications: Yes No
- Rhino lined bed and tailgate
 - Meets specifications: Yes No

Safety & Other

- Paper copies of Service, Repair, and Parts Manuals (to be supplied upon delivery)
 - Meets specifications: Yes No
- One complete set of filters shall be provided
 - Meets specifications: Yes No

Warranty and Training

TRAINING AND DIAGNOSTICS:

With delivery of the vehicle, a qualified representative shall instruct County Operators and Mechanics in the proper operation, servicing, lubrication, adjustments, and preventative maintenance of the equipment, including the crane.

Vendor will provide, in letter form only, type of warranty supplied on quoted equipment. The letter shall include type of service provided, guarantee of parts, and cost of service during warranty period. Vendor may also provide any other material which they feels gives their equipment an advantage on service and warranty. Please state any extended warranties and their associated cost in the warranty period.

The ability of bidder to provide superior warranty and service may be used to determine successful bidder.

Printed specifications on machine bid shall be presented. All above specifications filled in must be legible. With delivery of equipment and components, Manufacturer's Statement of Origin shall be supplied.

Additional Notes:

- A. The respondent shall provide the following information for each proposed system:
1. A complete bid including all related costs for providing the equipment, supplies and installation as outlined above.
 2. Delivery of all equipment, supplies, and installation.
 3. Enter into a written contract for work with Laramie County.
 4. Contractor shall comply with all applicable Federal and State statutes and regulations as well as local ordinances.
- B. The person or persons provided by the respondent to complete work shall be fully qualified to provide said services.
- C. All work provided by the respondent shall be in conformance with local, state, and Federal rules and regulations.
- D. All equipment shall be responsive to the needs of the County, shall be performed in accordance with County programs, policies, and procedures, and shall utilize appropriate methods and techniques.
- E. All records, including digital information, video tapes and audio tapes, related to the contract services performed for the County shall be subject to the Wyoming Public Records Laws and shall be maintained and made available in accordance with those laws and public records policies and procedures of the County. Records shall be made available to the County without question upon request of the County, in accordance with the requirements of law. Citizen requests for such records shall be processed through the County. All records, including all types of electronic records, related to the contract and services performed there under shall be the property of the County at the end of the contract, or at the end of the County's fiscal year, or upon demand of the County, whichever occurs first. The County shall specify the minimum records to be maintained by the respondent. The respondent may maintain additional records at its discretion.

3.0 General Terms & Conditions

3.1 RFB Closing Date

Bids must be received by the Laramie County Public Works Department (LCPW) at 13797 Prairie Center Circle, Cheyenne, Wyoming 82009 no later than **2:00 PM, MST, on January 4, 2024**. Bids received after this time will not be considered. Please note for bid delivery purposes, the hours of operation for LCPW are Monday through Thursday, 6:00 AM to 4:30 PM, MST.

3.2 Delivery of Bids

All bids shall be sealed and delivered or mailed to the address of Laramie County Public Works (faxes and emails will not be accepted).

3.3 Optional Pre-bid Information

No specific pre-bid meeting will be held. Each respondent shall contact John Poelma 307-633-4690 or john.poelma@laramiecountywy.gov to discuss the bid with the County, if needed.

3.4 Public RFB Opening

Only the names of the vendors submitting bids will be read aloud at the RFB opening. The bids will be available for inspection during normal business hours in the Laramie County Public Works Department within three (3) working days of the closing date, by appointment. Bid opening will occur on January 4, 2024, at 2:15 PM at the Laramie County Public Works office. A complete tabulation of bids will be available after it is completed.

Individuals covered by the Americans with Disabilities Act of 1990 in need of accommodations to attend public RFB openings or meetings should contact the Public Works Department in Cheyenne at (307) 633-4690 at least five (5) days prior to the date.

3.5 Bid Form

- A. See Submittal Requirements for complete details.
- B. Each respondent shall submit THREE (3) complete sets of the bid form, one marked "ORIGINAL" and TWO (2) marked "COPY". The bid shall be submitted on an exact copy of the attached bid form.
- C. The bid form must be signed by an official authorized to legally bind the respondent to all RFB provisions contained herein.
- D. Terms and conditions differing from those in this RFB may be cause for disqualification of the bid.

3.6 Questions Concerning RFB

Questions concerning any portion of this RFB should be directed in writing to John Poelma, Public Works Department, named below, who shall be the official point of contact for this RFB. Mark cover page or envelope(s) "Class 5 truck with Service Body".

Submit questions to:

John Poelma
Deputy Director
Public Works
(307) 633-4302

John.Poelma@laramiecountvwy.gov

3.7 Clarification and Addenda

It is incumbent upon each respondent to carefully examine all specifications, terms, and conditions contained herein. Any inquiries, suggestions, or requests concerning interpretation, clarification or additional information shall be made in writing, (facsimile transmissions

acceptable) through the Assistant Director named above. The County will not be responsible for any oral representation(s) given by any employee, representative or others. The issuance of a written addendum is the only official method by which interpretation, clarification or additional information can be given.

If it becomes necessary to revise or amend any part of this RFB, notice may be obtained by accessing the Laramie County web site. Respondents in their bid must acknowledge receipts of amendments. Each respondent should ensure that they have received all addenda and amendments to this RFB before submitting their bid. Please check the Laramie County web site at <http://www.laramiecountywv.gov> for any addenda.

3.8 Award

The County reserves the right to award the contract to the respondent(s) that the County deems to offer the best overall bid(s). The County is therefore not bound to accept a bid on the basis of lowest price. In addition, the County at its sole discretion, reserves the right to cancel this RFB, to modify the quantities of product we purchase, to reject any and all bids, to waive any and all informalities and/or irregularities, or to re-advertise with either the identical or revised specifications, if it is deemed to be in the best interest of the County to do so. The County also reserves the right to make multiple awards, based on experience and qualifications if it is deemed to be in the County's best interest.

3.9 Contract

The contents of this RFB and all provisions of the successful bid deemed pertinent by the County may be incorporated into a contract and become legally binding. A separate contract document will be issued.

The County Commissioners are the sole Contracting Officer for Laramie County, Wyoming, and only he/she or his/her designee is authorized to make changes to any contract. The County shall be responsible for only those orders placed by the County on an authorized signed Purchase Order or Price Agreement. The County shall not be responsible for any order, change, substitution or any other discrepancy from the Purchase Order or Price Agreement. If there is any question about the authenticity of a Purchase Order, Price Agreement or change order, the respondent should promptly contact the Public Works Department at (307) 633-4690.

3.10 Disclosure of RFB Content

All material submitted becomes the property of the County and may be returned only at the County's option. The County has the right to use any or all ideas presented in any reply to this RFB. Selection or rejection of any bid does not affect this right.

3.11 Respondent's Responsibility

A respondent, by submitting a bid represents that:

- A. The respondent has read and understands the RFB in its entirety that and the bid is made in accordance therewith, and**
- B. The respondent possesses the capabilities, resources, and personnel necessary to provide efficient and successful service to the County, and;**
- C. Before submitting a bid, each respondent shall make all investigations and examinations necessary to ascertain site and/or local conditions and requirements affecting the full performance of the contract and to verify any representations made by Laramie County upon which the respondent will rely. If the respondent receives an award because of its bid submission, failure to have made such investigations and examinations will in no way relieve the respondent from its obligations to comply in every detail with all provisions and requirements of the contract, nor will a plea of ignorance of such conditions and requirements be accepted as a basis for any claim by the respondent for additional compensation or relief.**

3.12 Payment Terms

The County will remit full payment on all undisputed invoices within forty-five (45) days from receipt by the appropriate person(s) (to be designated at time of contract) of the invoice(s) or receipt of all products or services ordered.

3.13 Minor Irregularities

The County reserves the right to waive minor irregularities in bids, providing such action is in the best interest of the County. Minor irregularities are defined as those that have no adverse effect on the County's best interests and will not affect the outcome of the selection process by giving the respondent an advantage or benefit not enjoyed by other respondents.

3.14 Deviations

All bids must clearly and with specific detail, note all deviations to the exact requirements imposed upon the respondent by the General Terms & Conditions. Such deviations must be stated upon the Bid Form; otherwise, Laramie County will consider the subject bids as being made in strict compliance with said General Terms & Conditions to respondents; the respondent being held therefore accountable and responsible. Respondents are hereby advised that Laramie County will only consider bids that meet the exact requirements imposed by the General Terms & Conditions; except, however, said bids may not be subject to such rejection where, at the sole discretion of Laramie County, the stated deviation is considered to be equal or better than the imposed requirement and where said deviation does not destroy the competitive character of the RFB process by affecting the amount of the bid such that an advantage or benefit is gained to the detriment of the other respondents.

3.15 Selection Criteria

Each bid shall be evaluated using the following criteria:

- 1. Proper submittal of ALL documentation as required by this bid**
- 2. Overall scope and quality of the proposed project**
- 3. Meeting or exceeding the requirements of the RFB**
- 4. Quality and compatibility of the work proposed**
- 5. Ability to accomplish project in a timely manner**
- 6. The benefits to Laramie County as it pertains to:**
 - a. Related experience in the areas covered in the RFB**
 - b. Past record of performance on contracts with government agencies and private industry with respect to such factors as control of costs, quality of work and ability to meet schedules**
 - c. Experience, ability, and overall quality of past and current projects**

3.16 Termination / Cancellation of Contract

The County reserves the right to cancel the contract without cause with a minimum thirty (30) days written notice. Termination or cancellation of the contract will not relieve the respondent of any obligations for any deliverables entered into prior to the termination of the contract (i.e., reports, materials, statements of accounts, etc., required and not received). Termination or cancellation of the contract will not relieve the respondent of any obligations or liabilities resulting from any acts committed by the respondent prior to the termination of the contract.

3.17 Incurred Expenses

This RFB does not commit Laramie County to award a contract. Nor shall Laramie County be responsible for any cost or expense which may be incurred by the respondent in preparing and submitting the bid called for in this RFB, or any cost or expense incurred by the respondent prior to the execution of a contract agreement.

3.18 Presentations by Respondents

Laramie County, at its sole discretion, may ask individual respondents to make oral presentations and/or demonstrations without charge to the County.

The County reserves the right to require any respondent to demonstrate to the satisfaction of the County that the respondent has the fiscal and managerial abilities to properly furnish the services proposed and required to fulfill the contract. The demonstration must satisfy the County and the County shall be the sole judge of compliance.

Respondents are cautioned not to assume that presentations will be required and should include all pertinent and required information in their original bid package.

3.19 Minimum Specifications

The specifications listed in the Scope of Service are the minimum required performance specifications for this RFB. They are not intended to limit competition nor specify any particular respondent, but to ensure that the County receives quality services.

3.20 Respondent's Personnel

The respondent shall be responsible for ensuring that its employees, agents and subcontractors comply with all applicable laws and regulations and meet all federal, state and local requirements related to their employment and position. The respondent certifies that it does not and will not during the performance of the contract employ illegal alien workers or otherwise violate the provisions of the federal Immigration Reform and Control Act of 1986, as amended. During the performance of the contract, the respondent agrees to the following:

The respondent shall not discriminate against any employee or applicant for employment because of race, religion, color, sex, age, handicap or national origin, except when such condition is a bona fide occupational qualification reasonably necessary for the normal operations of the respondent.

The respondent agrees to post in conspicuous places, visible to employees and applicants for employment, notices setting forth the provisions of this nondiscrimination clause.

The respondent, in all solicitations or advertisements for employees placed by or on behalf of the respondent, shall state that such respondent is an Equal Opportunity Employer.

3.21 Bid Acceptance/Rejection

The County reserves the right to accept or reject any or all bids received as a result of this RFB, or to negotiate separately with competing respondents, and to waive any informalities, defects, or irregularities in any bid, or to accept that bid or bids, which in the judgment of the proper officials, is in the best interest of the County.

4.0 Submittal Requirements

Bids shall include all the information solicited in this RFB, and any additional data that the respondent deems pertinent to the understanding and evaluating of the bid. Bids shall be organized, and sections tabbed in the following order. The respondent should not withhold any information from the written response in anticipation of presenting the information orally or in a demonstration, since oral presentations or demonstrations may not be solicited. All bids shall include at minimum:

Tab 1 – Respondent’s Profile

A brief profile of the firm, including the firm’s overall qualifications to provide services necessary to fulfill all requirements outlined in the project Scope of Work.

Tab 2 - Completed Bid Form (use attached form)

Tab 3 – References

List at least three (3) recent references where the equivalent project(s) have been conducted within the past five years.

Tab 4 – Other Information

Include any additional information you believe will assist the County in the selection process of qualified respondents. Please be succinct.

5.0 Disclosures

The laws of Wyoming require that the contents of all bids shall be placed in the public domain and be open to inspection by interested parties. Trade secrets or proprietary information that are recognized as such and are protected by law may be withheld if clearly identified as such in the bid. The entire bid cannot be designated as proprietary or a trade secret. If a request is received to examine portions designated as proprietary or a trade secret, Laramie County will notify the vendor to permit the vendor to defend the proprietary nature of the information.

If a respondent discovers any ambiguity, conflict, discrepancy, exclusionary specifications, omission, or other error in this document, the respondent shall immediately notify the issuing office. If the respondent is awarded a contract, then such respondent will not be entitled to additional compensation, relief, or time by reason of the error or its later correction.

The successful respondent will be expected to enter into a contract with Laramie County upon terms acceptable to the County. Respondent will be required to be registered in Sam.gov to receive federal ARPA funding as a contractor/vendor to this RFB.

Following the award of the contract, responses to this bid are subject to release as public information unless specific parts of the response can be shown to be exempt from the laws of the State of Wyoming. Respondents are advised to consult with their legal counsel regarding disclosure issues and take the appropriate precautions to safeguard trade secrets or any other proprietary information. Laramie County assumes no obligation or responsibility for asserting legal arguments on behalf of potential respondents.

If a respondent believes that parts of a bid are confidential then the respondent must so specify. The respondent must mark in bold red letters the term “CONFIDENTIAL” on that part of the response, which the respondent believes to be confidential. The respondent must submit in

writing specific detailed reasons, including any relevant legal authority, stating why the respondent believes the material to be confidential. Vague and general claims as to confidentiality will not be accepted. Laramie County will be the sole judge as to whether a claim is general and/or vague in nature. All parts of bids, which are not marked as confidential, will be automatically considered public information after the contract is awarded. The successful bid may be considered public information even though parts are marked confidential.

Bids must be signed by a person authorized to commit the respondent to provide the services requested in this RFB. Submission of a signed bid will be interpreted to mean the respondent has agreed to all terms and conditions set forth in all of the sheets which make up this RFB.

Laramie County accepts no obligations for the costs incurred in responding to this RFB in anticipation of being awarded a contract. Laramie County reserves the right to reject any and all submitted bids. It is understood that all bids become the property of Laramie County and will be available for public inspection. No obligation is made by retention of these bids, nor is Laramie County committed to awarding a contract as a result of this RFB.

Each respondent must disclose any existing or potential conflict of interest relative to the performance of the requirements of this bid. Examples of potential conflicts may include an existing business or personal relationship between the respondent, its principal or any affiliate or subcontractor, with Laramie County or any other entity or person involved in any way in the project that is the subject of this RFB. Similarly, any personal or business relationship between the respondent, the principals, or an affiliate or subcontractor, with any employee of Laramie County or its suppliers must be disclosed. Any such relationship that might be perceived or represented as a conflict should be disclosed. Failure to disclose any such relationship or reveal personal relationships with Laramie County employees may be cause for contract termination. Laramie County will decide if an actual or perceived conflict should result in bid disqualification. By submitting a response to this RFB, all respondents affirm that they have not given, nor intend to give, any time hereafter any economic opportunity, future employment, gift, loan, gratuity, special discount, tip, favor, or service to a Laramie County employee or representative in connection with the procurement.

Governmental Immunity

Laramie County does not waive its Governmental/Sovereign Immunity, as provided by any applicable law including W.S. 1-39-101 et seq., by issuing this RFB or by entering into any subsequent agreement. Further, Laramie County fully retains all immunities and defenses provided by law with regard to any action, whether in tort, contract or any other theory of law, based on this RFB or any subsequent agreement.

Indemnification

To the fullest extent permitted by law, the successful respondent agrees to indemnify and hold harmless Laramie County, its appointed officials, elected officials, employees and volunteers from any and all liability for injuries, damages, claims, penalties, actions, demands or expenses

arising from or in connection with any work performed by or on behalf of respondent for Laramie County pursuant to any agreement with Laramie County.

Termination

The selection may be terminated (a) by either party at any time for failure of the other party to comply with the terms and conditions of the RFB or any subsequent agreement; (b) by either party, with thirty days' prior written notice to the other party; or (c) upon mutual written agreement by both parties.

Force Majeure

Neither the respondent nor Laramie County shall be liable to perform under this RFB or subsequent agreement if such failure arises out of causes beyond control, and without the fault or the negligence of said party. Such causes may include, but are not restricted to, Act of God or the public enemy, fires, floods, epidemics, quarantine restrictions, freight embargoes and unusually severe weather. In every case, however, a failure to perform must be beyond the control and without the fault or the negligence of said party.

The submission of a bid shall be considered acceptance to all the terms and conditions provided herein and in the various bid documents, unless specifically noted otherwise in the bid.

[REMAINDER OF PAGE LEFT INTENTIONALLY BLANK]

6.0 BID FORM (Attachment)

TO: John Poelma
13797 Prairie Center Circle
Cheyenne, WY 82009
(307) 633-4302

The undersigned hereby declares that [firm name] Ko's Brothers Equipment

have carefully examined the specifications to furnish: **One (1) new Class 5 Truck with Service Body** for which bids were advertised to be received no later than 2:00 PM, MST, January 4, 2024 and further declare that [firm name]

Ko's Brothers Equipment will furnish the said work according to specifications.

Proposed Cost Total Estimated Cost for Project: \$ 158,398.⁰⁰

The above prices are all inclusive; County shall pay no other forms of compensation. The County reserves the right to add additional related services that were not known at the time of the publishing of this RFB to any resulting contract, upon negotiations with awarded contractors that is mutually agreeable.

Have you supplied the Submittal Requirements outlined above? YES NO

Laramie County reserves the right to reject any or all bids, to waive informalities, and to accept all or any part of any bid as they may deem to be in the best interest of the County.

I hereby certify that I have read and understand the requirements of this Request for Bids and, that I as the respondent, will comply with all requirements, and that I am duly authorized to execute this bid/offer document and any contract(s) and/or other transactions required by award of this RFB.

Company Ko's Brothers Equipment

By Jesse McKinley (Print name)

Signature [Signature]

Address 5200 Colorado Blvd

City Commerce City State CO ZIP 80022

Telephone (307) 760-1029 Fax (303) 298-8527

E-Mail Address: j.mckinley@ko'sbrothers.com

DUNS# 04-812-9050

Laramie County Public Works
13797 Prairie Center Circle
Cheyenne, WY 82009

Request For Bids
Class 5 Truck w/ Service Body

Tab 3 – References

Colorado Department of Transportation
1346 Tower Road
Aurora, CO 80011
(303) 365-7348

We've had the CDOT Contract for Service Trucks for the last 4 years.
Built a few dozen for CDOT

Laramie County Public Works
13797 Prairie Center Circle
Cheyenne, WY 82009

Request For Bids
Wheel Loader Mounted Snow Blower

Tab 1 – Respondants Profile

Company History

Kois Brothers Equipment Company was established in 1968 as a manufacturer of commercial solid waste containers, and custom truck bodies. In the 1970's the company expanded into the distribution of machinery and truck mounted equipment for truck chassis ranging from Class3 up to Class 8.

Kois Brothers is a full line equipment distribution company supporting city, county, state, federal government and private industry with a variety of quality products that utilize sophisticated electrical and hydraulic systems.

Organizational Structure

We have three brick and mortar locations with service technicians and parts inventory.
5200 Colorado Blvd. Commerce City, CO 80022
2107 Harnish Blvd. Billings, MT 59101
1610 River Drive North. Great Falls, MT59401
Jesse McKinley is the territory sales representative that lives in Cheyenne, Wyoming.

Ownership Interests

Kois Brothers is owned and operated by three brothers; Garry, Ernie and Scott.

Active Business Venue

Kois Brothers operates in Montana, Wyoming, Nebraska Panhandle and Colorado.

Present Status and Projected Corporate Direction

Kois Brothers has been in the truck and equipment business for over 50 years. We strive to supply the highest quality of equipment so that customer up time in field is maximized.

Overall Qualifications to Provide Summary of Equivalent Services as the Scope of Work

Kois Brothers has been providing LaRue snow blower products since 2012. We have installed equipment, trained operators and repair staff on LaRue equipment for both loader mounted and purpose-built airport runway brooms.

We have a staff of technician's factory trained and ASE certified Master Truck Equipment technicians, including E1R installation & repair, E2R electrical/electronic systems, E3R auxiliary power systems. Our staff is trained on LaRue Products and participates in LaRue offered training. LaRue offers 24-7 factory support.

K O I S EQUIPMENT COMPANY INC.

DENVER
5200 Colorado Blvd.
Commerce City, CO 80022
Phone: 303-298-7370
Fax: 303-298-8527

BILLINGS
2107 Hamish Blvd.
Billings, MT 59101
Phone: 406-652-3975
Fax: 406-652-3744

GREAT FALLS
1610 River Drive North
Great Falls, MT 59401
Phone: 406-452-2757
Fax: 406-452-2799

DATE 01/ 4/24 PAGE 1
QUOTE NO. 24-1601
*** QUOTE ***

SOLD TO:
LARAMIE COUNTY PUBLIC WORKS
13797 PRAIRIE CENTER CIRCLE

CHEYENNE WY 82009

SHIP TO:
LARAMIE COUNTY PUBLIC WORKS
13797 PRAIRIE CENTER CIRCLE

CHEYENNE WY 82009

```
=====
CUSTOMER PO      CUSTOMER NUM    SHIP VIA      SALESMAN  TERMS      CUSTOMER PHONE
BID              12380          DELIVERED     716       N10        307-633-4302
=====
```

Laramie County,
We are pleased to submit the following quotation for your consideration. We strive to supply the highest of quality equipment so that your up time is maximized. Please review the quote and let me know if you have any other questions. We look forward to meeting your equipment needs and building a product that will last for years to come. Thank you for your interest.
Sincerely,

Jesse McKinley
307-760-1029

| PART NUMBER | DESCRIPTION | QTY ORD | UOM | PRICE | EXTENDED |
|--------------------|---------------------------------------------------|---------|-----|-----------|-----------|
| STELLAR TMAX1-9 | *9' steel crane body alu doors | 1.00 | EA | 44,181.00 | 44,181.00 |
| STELLAR EC6000 | *Electric/hydraulic crane | 1.00 | EA | 23,298.00 | 23,298.00 |
| OUTRIGGERS | *electric/hyd, built into bmpr | 1.00 | EA | 6,676.00 | 6,676.00 |
| BOOM SUPPORT | *amp spring reinforcement | 1.00 | EA | 2,035.00 | 2,035.00 |
| 3500 WATT INVERTER | *w/ battery and outlet | 1.00 | EA | 1,500.00 | 1,500.00 |
| LABOR INSTALL | INSTALLATION LABOR install and test | 50.00 | EA | 145.00 | 7,250.00 |
| MISC SUPPLIES | MISC SHOP SUPPLIES for mounting crane and body | 1.00 | EA | 400.00 | 400.00 |

All returned goods must be accompanied by invoice and are subject to handling charge after 30 days.

NO RETURNS AFTER 90 DAYS

A SERVICE CHARGE OF 2% PER MONTH, 24% PER ANNUM WILL BE ADDED TO ANY INVOICE NOT PAID BY THE LAST DAY OF THE MONTH IN WHICH IT IS DUE. WE ARE CONFORMING WITH THE FAIR LABOR STANDARDS ACT OF 1938 AS AMENDED. NOT RESPONSIBLE FOR TIMELOST DUE TO FIRES, STRIKES OR CAUSES BEYOND OUR CONTROL. STENOGRAPHICAL AND CLERICAL ERRORS SUBJECT TO CORRECTION
THANK YOU FOR ALLOWING US TO QUOTE THESE ITEMS. YOUR COST IS

Sub Total 85,340.00
Sales Tax 0.00
F.E.T. 0.00
Freight 3,750.00

TOTAL 89,090.00



Preview Order U300 - X5H 4x4 Super Chas Cab DRW: Order Summary Time of Preview: 01/04/2024 09:07:42 Receipt: NA

Dealership Name: Ken Garff Ford Cheyenne

Sales Code : F56422

| | | | | | | | |
|---------------|---------------|---------------|-------|--------------|-----------|-------------|------|
| Dealer Rep. | RONALD DOWNEY | Type | Fleet | Vehicle Line | Superduty | Order Code | U300 |
| Customer Name | Laramie Co. | Priority Code | B1 | Model Year | 2024 | Price Level | 425 |

| DESCRIPTION | MSRP | DESCRIPTION | MSRP |
|--------------------------------|---------|------------------------------|--------|
| F550 4X4 SUPERCAB CHAS CAB/168 | \$59130 | 4.10 RATIO REGULAR AXLE | \$0 |
| 168 INCH WHEELBASE | \$0 | JOB #2 ORDER | \$0 |
| TOTAL BASE VEHICLE | \$59130 | 18000# GVWR PACKAGE | \$0 |
| OXFORD WHITE | \$0 | 50 STATE EMISSIONS | \$0 |
| CLOTH 40/20/40 SEAT | \$100 | 40 GAL AFT OF AXLE FUEL TNK | \$0 |
| MEDIUM DARK SLATE | \$0 | PRICE CONCESSION INDICATOR | \$0 |
| PREFERRED EQUIPMENT PKG.660A | \$0 | REMARKS TRAILER | \$0 |
| .XL TRIM | \$0 | DUAL BATTERY | \$0 |
| .AIR CONDITIONING -- CFC FREE | \$0 | SPECIAL FLEET ACCOUNT CREDIT | \$0 |
| .AM/FM STEREO MP3/CLK | \$0 | FUEL CHARGE | \$0 |
| 6.7L POWER STROKE V8 DIESEL | \$9995 | PRICED DORA | \$0 |
| 10-SPEED AUTO TORQSHIFT | \$0 | ADVERTISING ASSESSMENT | \$0 |
| 225/70R19.5G BSW ALL POSITION | \$0 | DESTINATION & DELIVERY | \$1995 |

| | | |
|------------------------|------|---------|
| TOTAL BASE AND OPTIONS | MSRP | \$71220 |
| DISCOUNTS | NA | |
| TOTAL | | \$71220 |

ORDERING FIN: QE109 END USER FIN: QE109

INCENTIVES

Acc. Code ID :10 Contract/Ref # :21-170R Bid Date :07/24/23State : WY

KOIS Price \$ 67,494.00
 + FM 200
 \$ 67,694.00 DISCOUNTS: \$-100.00

Customer Name: Customer Email:
 Customer Address: Customer Phone:

Customer Signature Date

This order has not been submitted to the order bank.

This is not an invoice.



EC6000 ELECTRIC SERVICE CRANES

6,000-lb Capacity with 21' Horizontal Reach

Bring on the heavier challenges. Stellar[®] EC6000 Electric Service Cranes have you covered. They combine the lifting power you need with the economy you want, and operation is significantly quieter than hydraulic cranes so you can work at times and in locations where reduced noise is essential. Because you don't have to maintain separate hydraulic components, you save on labor time and parts. You can also lower chassis costs because EC6000 Electric Cranes let you use a gas or diesel chassis without the need to add a power take-off (PTO) and pump to the chassis or a transmission that can handle the PTO and pump.



ADDITIONAL INFORMATION

EC6000 Includes:

- **Ball Bearing Rotation Gear** for solid support and smooth operation
- **Steel Worm Gear** for reliable speed control when rotating the shaft
- **Electric Planetary Winch** that lifts the maximum crane load and offers the smoothest and fastest speeds in the market today for maximum productivity
- **Low-Profile Design** for superior clearance
- **Exclusive Double-Boom Design** for rigidity, strength and accuracy
- **Integral Rotation Stop** with 410° rotation for the greatest performance while protecting wires and hoses from damage
- **Certification** for ANSI B30.5 and OSHA 1910.180 specifications

SPECIFICATIONS

| | |
|------------------------------------|----------------------------------------------------------------------------------------|
| Crane Rating: | 38,000 ft-lbs (5.25 tm) |
| Standard Boom Length: | 11' (3.35 m) from CL of crane |
| Boom Extension: | |
| • 1st Stage: | Hydraulic 60" (152.4 cm) |
| • 2nd Stage: | Manual 60" (152.4 cm) |
| Maximum Horizontal Reach: | 21' (6.40 m) from CL of crane |
| Maximum Vertical Lift: | 22' 10" (6.96 m) from crane base |
| Lifting Capacity: | 6,000 lbs @ 6' 4" (2,720 kg @ 1.9 m) 1,810 lbs @ 21' (820 kg @ 6.4 m) |
| Boom Elevation: | -5° to +80° |
| Stowed Height (crane only): | 34.41" (87.4 cm) |
| Mounting Space Required: | 20" x 21" (50.8 x 53.3 cm) |
| Approximate Crane Weight: | 1,600 lbs (725 kg) |
| Controls: | Radio remote |
| Winch | |
| • Rope Diameter: | 5/16" (0.79 cm) |
| • Rope Length: | 90' (27.4 m) |
| • Line Pull Speed: | 16 ft/min (4.88 m/min) |
| • Max. Single Part Line: | 3,000 lbs (1,360 kg) |
| • Max. Double Part Line: | 6,000 lbs (2,720 kg) |
| Rotation: | 400° (worm gear) |
| Power Supply Required: | 12V power unit: 2 gpm @ 2,900 psi (7.57 lpm @ 200 bars) |
| Min. Rec. Chassis (GVRW)*: | 16,000 |

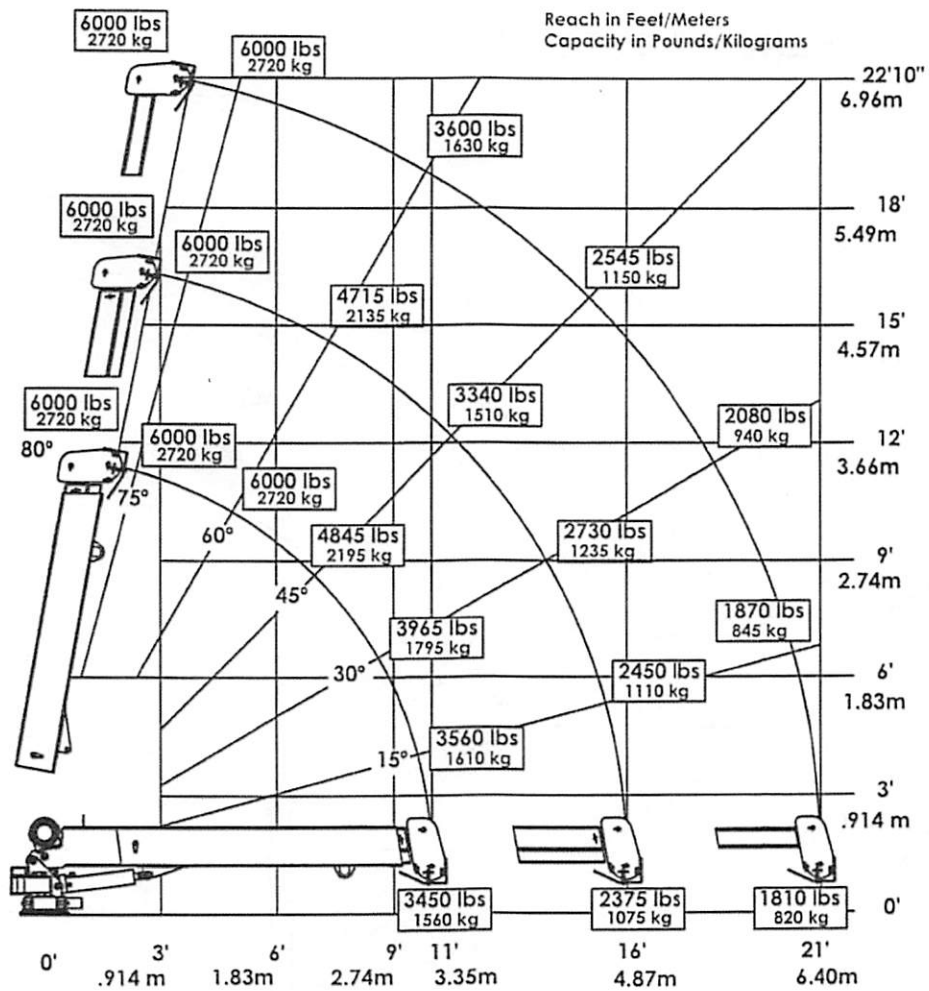

Weight of load handling devices are part of the load lifted and must be deducted from the capacity.

Maximum 1 - part line capacity is 3000 lbs (1360 kg). For greater loads, use 2 - part line.

STELLAR EC6000

PN 53525

Capacity Chart

■ SERVICE BODY MOUNT

Mounts on 20" deep (or larger) side packs.

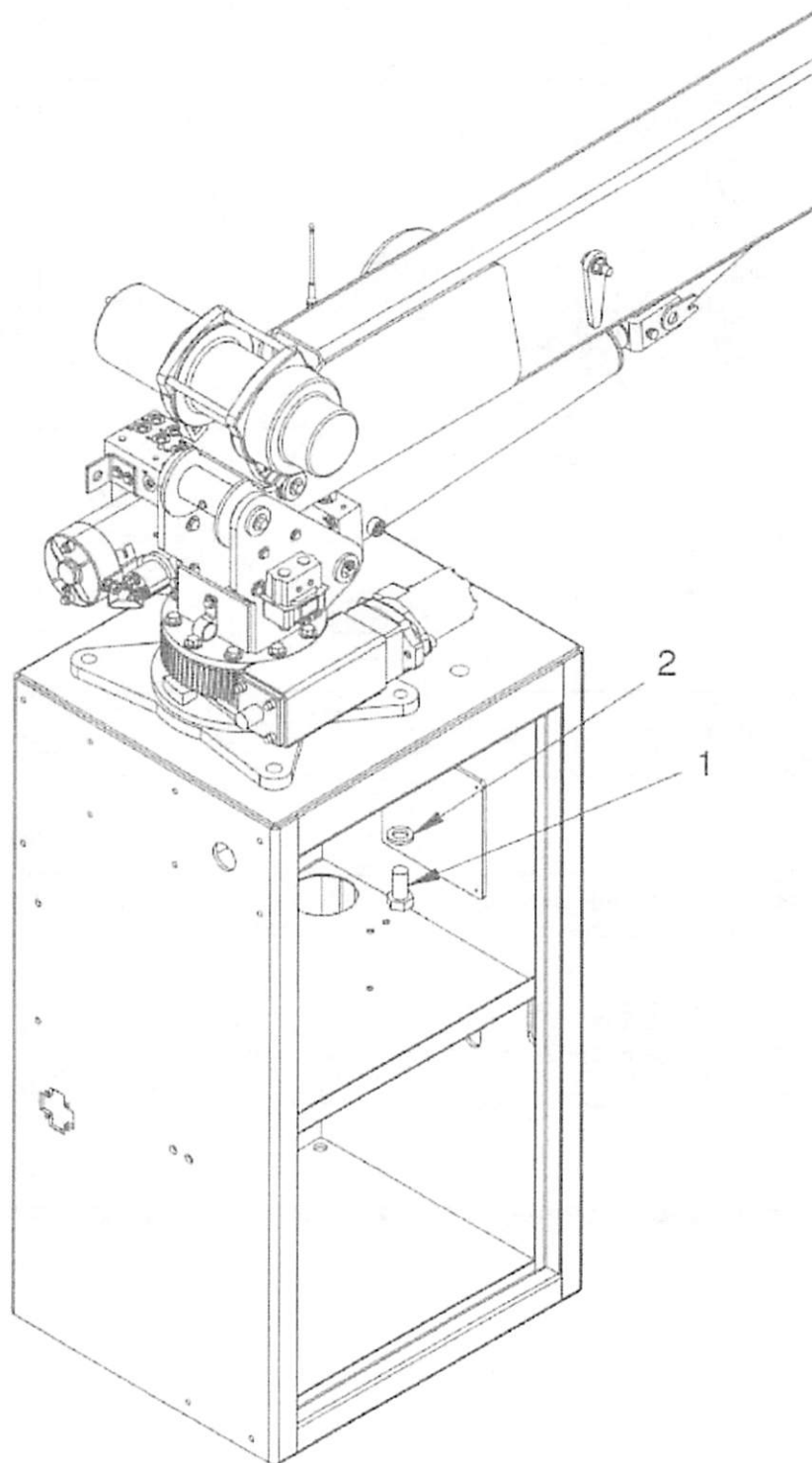

| Item | Part | Description | Qty. |
|------|------|-------------|------|
| | | | |

HOLE MOUNTING DETAIL

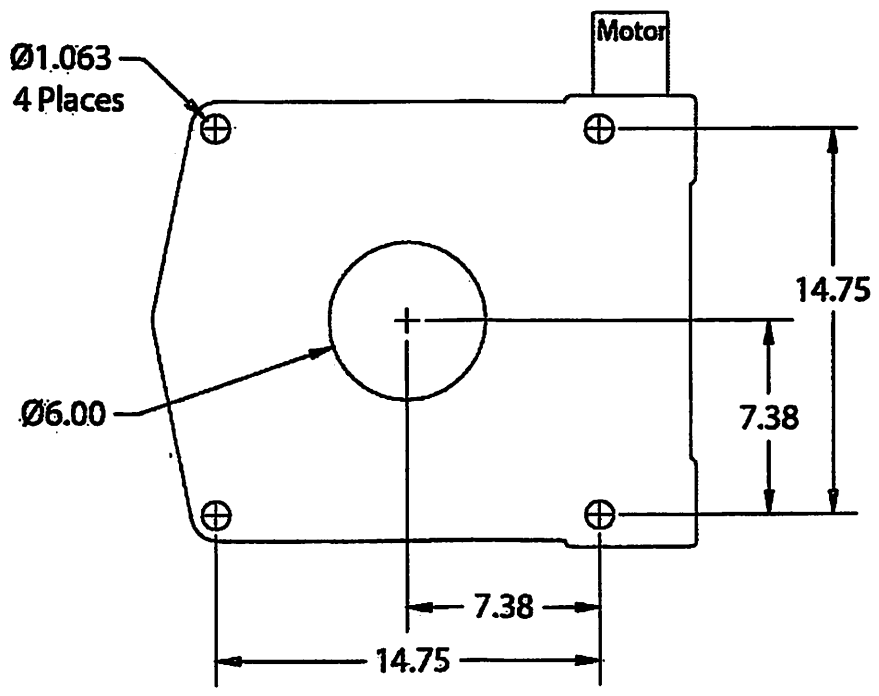

Hole Mounting Detail

■ ROTATIONAL CLEARANCE

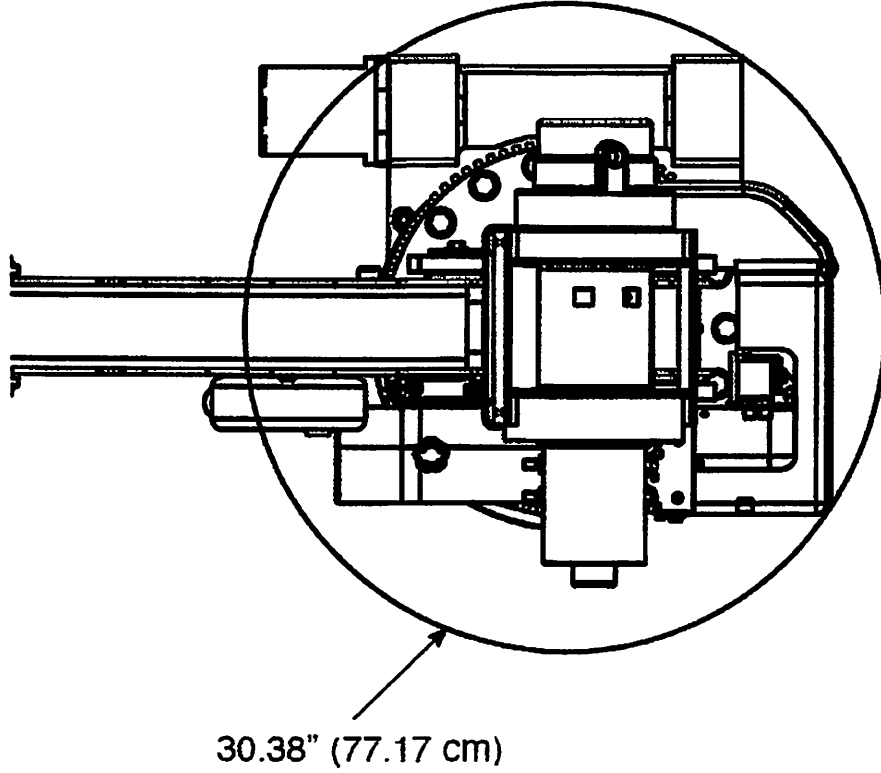

Rotational Clearance

■ GEOMETRIC DIMENSIONS

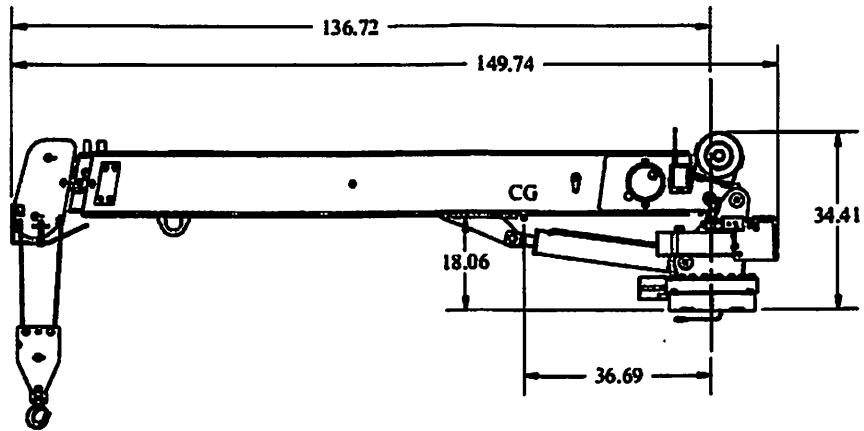
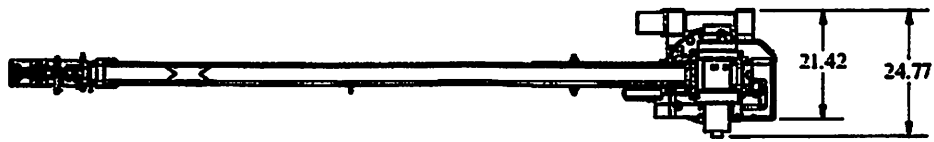

Dimensions

RESOURCES

- **Operation Manual**
- **Parts and Install Manual**
- **Crane Inspection Log**
- **Crane Comparison Chart**



190 State Street | Garner, Iowa 50438 | | 800.321.3741

© Stellar. All rights reserved.



TMAX™ 1

With extensive crane compatibility and customization options, TMAX 1 Mechanic Trucks have a wide range of applications covered. Available in aluminum and steel models, the quality is apparent in every element from the engineering to the materials to the precision construction.



ADDITIONAL INFORMATION

- Available in either 9' or 11' steel bodies or available in 9', 11', or 13' aluminum bodies.
- Stellar's torq-isolator crane support design isolates the crane compartment from the rest of the side pack.
- Lifting stresses are transferred to the stabilizers and box-type subframe, not the compartment doors.
- Aluminum extruded top with drill-free mounting rails make it easy to add a wide range of mechanic service truck accessories.
- Aluminum sidepack and doors reduce weight and corrosion, allowing for more payload and longer life.
- Bodies feature a 21" steel workbench bumper with an integrated full-width long bar storage compartment and vise mounts.
- Roller-type boom support helps center the crane boom when stowing.
- Stainless-steel billet-style hinges have hidden fasteners and a rugged 5/16" stainless-steel rod for years of heavy use.
- Rotating master-lock system for security.
- Exterior mounted light box provides easy mounting for lights and other accessories while minimizing entry points into the body.
- 3-point compression latches keep weather-stripping tight while allowing easy access.
- Double-panel 1/8" aluminum tailgate with hinged arm brackets provides a stout working surface.
- 250-lb capacity, adjustable divider shelves made of spangled galvanized steel.
- Complete undercoating, with minimum of 6.5 mils of petroleum base material, provides extra protection from corrosion and road debris.
- Easily add a wide range of mechanic service truck accessories.

Models

- TMAX 1-9 (steel and aluminum)
- TMAX 1-11 (steel and aluminum)
- TMAX 1-13 (aluminum)

Works with CDTpro™ Control System

Several cranes compatible with the TMAX 1 feature the new CDTpro Control System. Its innovative, industry-only Range Finder™ technology provides real-time max lifting capacity from any point as you walk around the crane.

SPECIFICATIONS

| | TMAX 1-9 | TMAX 1-11 | TMAX 1-13 |
|----------------------------|------------------------------------------------------------------------------------------------------------------------------------------------------------------------------------------------------------------------------------------------------------------------------------------------------------------------------|-------------------------------------------------------------------------------------------------------------------------------------------------------------------------------------------------------------------------------------------------------------------------------------------------------------------------------------------------------------------------------------------------------------------------------------------------------------------------------------------------|---------------------------------------------------------------------------------------------------------------------------------------|
| Applicable Chassis: | 16,000 – 22,900 GVWR (19.5 tire size) | 16,000 – 22,900 GVWR (19.5 tire size) | 22,000 – 22,900 GVWR (19.5 tire size) |
| Body Height: | <p>Steel:</p> <ul style="list-style-type: none"> • 44" (112 cm) • CS1V Raised to 60" (152 cm) remaining 44" (112 cm) <p>Aluminum:</p> <ul style="list-style-type: none"> • All Raised 52" (132 cm) • All Raised 52" (132 cm) with 8" (20 cm) drop well in CS1V | <p>Steel:</p> <ul style="list-style-type: none"> • 44" (112 cm) • CS1V Raised to 60" (152 cm) remaining 44" (112 cm) • All Raised 52" (132 cm) • All Raised 52" (132 cm) with 8" (20 cm) drop well in CS1V <p>Aluminum:</p> <ul style="list-style-type: none"> • 44" (112 cm) • All Raised 52" (132 cm) • All Raised 52" (132 cm) with 8" (20 cm) drop well in CS1V • All Raised 60" (152 cm) | <p>Aluminum:</p> <ul style="list-style-type: none"> • All Raised 52" (132 cm) with 8" (20 cm) drop well in CS1V |
| Body Width: | 94" (239 cm) | 94" (239 cm) | 94" (239 cm) |
| Floor Width: | 50" (127 cm) | 50" (127 cm) | 50" (127 cm) |
| Compartment Depth: | 22" (56 cm) | 22" (56 cm) | 22" (56 cm) |
| Clear Cab to Axle: | 60" (152 cm) | 84" (213 cm) | 108" (274cm) |
| Body Length: | 109" (277 cm) | 133" (338 cm) | 157" (399 cm) |
| Net Weight: | <p>Steel: 3,149 - 3,222 lbs (1,428 - 1,462 kg)</p> <p>Aluminum: 2,718 – 2,728 lbs (1,233 – 1,237 kg)</p> | <p>Steel: 3,604 - 4,076 lbs (1,635 - 1,849 kg)</p> <p>Aluminum: 2,851 - 3,146 lbs (1,293 - 1,427kg)</p> | <p>Aluminum: 3,330 lbs (1,293 - 1,511 kg)</p> |

COMPATIBLE CRANES

| | Crane Rating | Max. Reach | Max. Capacity | Control Systems |
|----------------------------------|---------------------|-------------------|----------------------|------------------------|
| Electric Cranes | | | | |
| EC3200 | 11,500 ft-lb | 15' (4.57 m) | 3,200 lbs (1,451 kg) | |
| EC6000 | 38,000 ft-lb | 21' (6.40 m) | 6,000 lbs (2,722 kg) | |
| Electric-Hydraulic Cranes | | | | |
| 3315 | 11,500 ft-lb | 15' (4.57 m) | 3,200 lbs (1,451 kg) | CDT™ |
| 4421 | 16,000 ft-lb | 21' (6.40 m) | 4,000 lbs (1,810 kg) | CDT™ |
| 5521 | 29,500 ft-lb | 21' (6.40 m) | 5,000 lbs (2,268 kg) | CDT™ |
| 6521 | 35,000 ft-lb | 21' (6.40 m) | 6,000 lbs (2,722 kg) | CDT™ |
| Hydraulic Cranes | | | | |
| 7621 | 44,840 ft-lb* | 21' (6.40 m) | 7,500 lbs (3,400 kg) | CDTpro™ |
| 7630 | 44,840 ft-lb* | 29' 8" (9.04 m) | 7,500 lbs (3,400 kg) | CDTpro™ |
| 8621 | 53,100 ft-lb* | 21' (6.40 m) | 8,600 lbs (3,900 kg) | CDTpro™ |
| 8630 | 53,100 ft-lb* | 29' 8" (9.04 m) | 8,600 lbs (3,900 kg) | CDTpro™ |

RESOURCES

- **TMAX™ Series Brochure**
- **Product Manual**

AWARDS



VIDEOS



190 State Street | Garner, Iowa 50438 | 800.321.3741

© Stellar. All rights reserved.



KOIS BROTHERS EQUIPMENT CO., INC.

| | | |
|--------------------------------------------------------------------------------------------------------|-------------------------------------------------------------------------------------------------------|----------------------------------------------|
| Unique Entity ID SYTPGGN99HY1 | CAGE / NCAGE 1KJA5 | Purpose of Registration All Awards |
| Registration Status Active Registration | Expiration Date Jan 9, 2025 | |
| Physical Address 5200 Colorado BLVD Commerce City, Colorado 80022-3715 United States | Mailing Address 5200 Colorado BLVD Commerce City, Colorado 80022-3715 United States | |

Business Information

| | | |
|----------------------------------------------|---------------------------------------------------------------------|--------------------------------|
| Doing Business as (blank) | Division Name Colorado | Division Number 1 |
| Congressional District Colorado 01 | State / Country of Incorporation Colorado / United States | URL koisbrothers.com |

Registration Dates

| | | |
|----------------------------------------|----------------------------------------|--------------------------------------------------|
| Activation Date Jan 12, 2024 | Submission Date Jan 10, 2024 | Initial Registration Date Feb 19, 2002 |
|----------------------------------------|----------------------------------------|--------------------------------------------------|

Entity Dates

| | |
|------------------------------------------|---------------------------------------------|
| Entity Start Date May 29, 1969 | Fiscal Year End Close Date Dec 31 |
|------------------------------------------|---------------------------------------------|

Immediate Owner

| | |
|------------------------|---------------------------------------|
| CAGE (blank) | Legal Business Name (blank) |
|------------------------|---------------------------------------|

Highest Level Owner

| | |
|------------------------|---------------------------------------|
| CAGE (blank) | Legal Business Name (blank) |
|------------------------|---------------------------------------|

Executive Compensation

Registrants in the System for Award Management (SAM) respond to the Executive Compensation questions in accordance with Section 6202 of P.L. 110-252, amending the Federal Funding Accountability and Transparency Act (P.L. 109-282). This information is not displayed in SAM. It is sent to USAspending.gov for display in association with an eligible award. Maintaining an active registration in SAM demonstrates the registrant responded to the questions.

Proceedings Questions

Registrants in the System for Award Management (SAM.gov) respond to proceedings questions in accordance with FAR 52.209-7, FAR 52.209-9, or 2. C.F.R. 200 Appendix XII. Their responses are displayed in the responsibility/qualification section of SAM.gov. Maintaining an active registration in SAM.gov demonstrates the registrant responded to the proceedings questions.

Exclusion Summary

Active Exclusions Records?
No

SAM Search Authorization

I authorize my entity's non-sensitive information to be displayed in SAM public search results:
Yes

Entity Types

| | | |
|--------------------------------------------------------------|---------------------------------|------------------------------|
| Business Types | Entity Type | Organization Factors |
| Entity Structure Corporate Entity (Not Tax Exempt) | Business or Organization | Manufacturer of Goods |
| Profit Structure For Profit Organization | | |

Socio-Economic Types

Check the registrant's Repts & Certs, if present, under FAR 52.212-3 or FAR 52.219-1 to determine if the entity is an SBA-certified HUBZone small business concern. Additional small business information may be found in the SBA's Dynamic Small Business Search if the entity completed the SBA supplemental pages during registration.

Financial Information

| | |
|--------------------------------------------|-------------------------------------|
| Accepts Credit Card Payments Yes | Debt Subject To Offset No |
| EFT Indicator 0000 | CAGE Code 1KJA5 |

Points of Contact

Electronic Business

| | |
|-------------------------------------|-----------------------------------------------------------------------|
| Ernest Kois, VP Finance | 5200 Colorado BLVD Commerce City, Colorado 80022 United States |
| Gregory S Shelhammer, Administrator | 5200 Colorado BLVD Commerce City , Colorado 80022 United States |

Government Business

| | |
|---------------------------|-----------------------------------------------------------------------|
| Gary G Kois, President | 5200 Colorado BLVD Commerce City, Colorado 80022 United States |
| Scott Kois, VP Operations | 5200 Colorado BLVD Commerce City , Colorado 80022 United States |

Past Performance

| | |
|-------------------------|-----------------------------------------------------------------------|
| Gary Kois, President | 5200 Colorado BLVD. Commerce City, Colorado 80022 United States |
| Ernest Kois, VP-Finance | 5200 Colorado BLVD. Commerce City, Colorado 80022 United States |

Service Classifications

NAICS Codes

| Primary | NAICS Codes | NAICS Title |
|---------|-------------|----------------------------------------------------------------------------------------|
| Yes | 336211 | Motor Vehicle Body Manufacturing |
| | 332313 | Plate Work Manufacturing |
| | 423810 | Construction And Mining (Except Oil Well) Machinery And Equipment Merchant Wholesalers |
| | 811111 | General Automotive Repair |
| | 811198 | All Other Automotive Repair And Maintenance |

Product and Service Codes

| | |
|------|--------------------------------------------------------------------|
| PSC | PSC Name |
| AS21 | R&D- Modal Transportation: Surface Motor Vehicles (Basic Research) |

Disaster Response

This entity does not appear in the disaster response registry.

Ken Garff

ORIGINAL

**KEN GARFF FORD – CHEYENNE
CLASS 5 TRUCK WITH SERVICE BODY
BID DATE: 01/04/2024 AT 2:00PM**

KEN GARFF CHEYENNE
2200 WESTLAND RD
CHEYENNE, WY 82001

Ken Garff Automotive Group

The Ken Garff Automotive Group started in downtown Salt Lake City in 1932. It was established based on the principles of integrity, honesty and personalized customer service. The company has grown over the last 90+ years to include more than 70 dealerships throughout the country. The Ken Garff Automotive Group purchased the Ford dealership in Cheyenne in 2021. The Commercial Vehicle Center at the Ford store in Cheyenne has continued to provide supreme customer service for the commercial and fleet customers' needs throughout Wyoming, western Nebraska and northern Colorado for more than 15 years.

KEN GARFF CHEYENNE
2200 WESTLAND RD
CHEYENNE, WY 82001

REQUEST FOR BIDS
Laramie County Public Works
One (1) new Class 5 Truck with Service Body
Closing Date: January 4, 2024

Purpose of Request for Bids (RFB)

Laramie County is soliciting competitive bids for qualified vendors who can provide one (1) new Class 5 Truck with Service Body for Laramie County Public Works. This project is being funded with Federal ARPA funds (ALN # 21.027) and selected vendor will be required to be registered in sam.gov.

Table of Contents

1.0 PURPOSE & OVERVIEW 2

2.0 SCOPE OF SERVICES 2

3.0 GENERAL TERMS & CONDITIONS 5

 3.1 RFB CLOSING DATE 5

 3.2 DELIVERY OF BIDS 5

 3.3 PRE-BID INFORMATION 6

 3.4 PUBLIC RFB OPENING 6

 3.5 BID FORM 6

 3.6 QUESTIONS CONCERNING RFB 6

 3.7 CLARIFICATION AND ADDENDA 6

 3.8 AWARD 7

 3.9 CONTRACT 7

 3.10 DISCLOSURE OF RFB CONTENT 7

 3.11 RESPONDENT'S RESPONSIBILITY 8

 3.12 PAYMENT TERMS 8

 3.13 MINOR IRREGULARITIES 8

 3.14 DEVIATIONS 8

 3.15 SELECTION CRITERIA 9

 3.16 TERMINATION / CANCELLATION OF CONTRACT 9

 3.17 INCURRED EXPENSES 9

 3.18 PRESENTATIONS BY RESPONDENTS 9

 3.19 MINIMUM SPECIFICATIONS 10

 3.20 RESPONDENT'S PERSONNEL 10

 3.21 BID ACCEPTANCE/REJECTION 10

4.0 4.0 SUBMITTAL REQUIREMENTS 10

5.0 5.0 DISCLOSURES 11

6.0 BID FORM 14

KEN GARFF CHEYENNE
 2200 WESTLAND RD
 CHEYENNE, WY 82001

1.0 Purpose & Overview

Laramie County Public Works is soliciting competitive, sealed bids from qualified vendors to provide one (1) new Class 5 Truck with Service Body.

2.0 Scope of Services

Specifications for Bid

The winning bidder must be registered with sam.gov

Estimated date of delivery: 180-300+ days ARD Subject to production availability

General

- Extended cab truck chassis (Cab color must be white) (8-foot bed/chassis length min)
 - Meets specifications: Yes No
- Gasoline/Diesel powered engine (Describe engine under bid proposal)
Bid proposal 6.7 L V-8 Diesel
- Class 5 Chassis (GVWR between 16,000 and 19,500)
 - Meets specifications: Yes No
- Four-wheel drive
 - Meets specifications: Yes No
- Dual rear wheels
 - Meets specifications: Yes No
- Automatic transmission
 - Meets specifications: Yes No
- Limited Slip Rear Axle
x • ~~Locking~~ rear axle
 - Meets specifications: Yes No Limited Slip 4.30 rear axle
- 250 Amp alternator
 - Meets specifications: Yes No
- Engine block heater
 - Meets specifications: Yes No
- Cruise control
 - Meets specifications: Yes No

- Rear vision camera
 - Meets specifications: Yes No
- Uplifter switches
 - Meets specifications: Yes No
- Air conditioning
 - Meets specifications: Yes No
- AM/FM radio (Bluetooth)
 - Meets specifications: Yes No
- Rubber floor mats
 - Meets specifications: Yes No

Service Body Specs

- 6,000-pound hydraulic service crane (20–26-foot reach)
 - Meets specifications: Yes No
- Wireless crane controls
 - Meets specifications: Yes No
- Hydraulic out riggers
 - Meets specifications: Yes No
- Drawer sections in all driver's side cabinets
 - Meets specifications: Yes No
- Front torch storage cabinet (vented and reinforced)
 - Meets specifications: Yes No
- Tool storage rear bumper (with vice mounted on it)
 - Meets specifications: Yes No
- Tie downs in bed
 - Meets specifications: Yes No
- Steel Aluminum doors (with weather stripping and locking handles)
 - Meets specifications: Yes No
- Cabinet lighting
 - Meets specifications: Yes No
- LED flood lights (x6)
 - Meets specifications: Yes No

KEN GARFF CHEYENNE
 2200 WESTLAND RD
 CHEYENNE, WY 82001

- 360-Degree beacon LED warning strobes – Amber (low profile)
 - Meets specifications: Yes No
- Adjustable cabinet shelving (for passenger side cabinets)
 - Meets specifications: Yes No
- Tailgate
 - Meets specifications: Yes No
- Reinforced welder mount (for Miller Bobcat 250)
 - Meets specifications: Yes No
- 3,500-watt inverter (with 120-volt outlet wired into bed)
 - Meets specifications: Yes No
- Rhino lined bed and tailgate
 - Meets specifications: Yes No

Safety & Other

- Paper copies of Service, Repair, and Parts Manuals (to be supplied upon delivery)
 - Meets specifications: Yes No
- One complete set of filters shall be provided
 - Meets specifications: Yes No

Warranty and Training

TRAINING AND DIAGNOSTICS:

With delivery of the vehicle, a qualified representative shall instruct County Operators and Mechanics in the proper operation, servicing, lubrication, adjustments, and preventative maintenance of the equipment, including the crane.

Vendor will provide, in letter form only, type of warranty supplied on quoted equipment. The letter shall include type of service provided, guarantee of parts, and cost of service during warranty period. Vendor may also provide any other material which they feels gives their equipment an advantage on service and warranty. Please state any extended warranties and their associated cost in the warranty period.

The ability of bidder to provide superior warranty and service may be used to determine successful bidder.

Printed specifications on machine bid shall be presented. All above specifications filled in must be legible. With delivery of equipment and components, Manufacturer's Statement of Origin shall be supplied.

KEN GARFF CHEYENNE
2200 WESTLAND RD
CHEYENNE, WY 82001

Additional Notes:

- A. The respondent shall provide the following information for each proposed system:
 - 1. A complete bid including all related costs for providing the equipment, supplies and installation as outlined above.
 - 2. Delivery of all equipment, supplies, and installation.
 - 3. Enter into a written contract for work with Laramie County.
 - 4. Contractor shall comply with all applicable Federal and State statutes and regulations as well as local ordinances.

- B. The person or persons provided by the respondent to complete work shall be fully qualified to provide said services.

- C. All work provided by the respondent shall be in conformance with local, state, and Federal rules and regulations.

- D. All equipment shall be responsive to the needs of the County, shall be performed in accordance with County programs, policies, and procedures, and shall utilize appropriate methods and techniques.

- E. All records, including digital information, video tapes and audio tapes, related to the contract services performed for the County shall be subject to the Wyoming Public Records Laws and shall be maintained and made available in accordance with those laws and public records policies and procedures of the County. Records shall be made available to the County without question upon request of the County, in accordance with the requirements of law. Citizen requests for such records shall be processed through the County. All records, including all types of electronic records, related to the contract and services performed there under shall be the property of the County at the end of the contract, or at the end of the County's fiscal year, or upon demand of the County, whichever occurs first. The County shall specify the minimum records to be maintained by the respondent. The respondent may maintain additional records at its discretion.

3.0 General Terms & Conditions

3.1 RFB Closing Date

Bids must be received by the Laramie County Public Works Department (LCPW) at 13797 Prairie Center Circle, Cheyenne, Wyoming 82009 no later than **2:00 PM, MST, on January 4, 2024**. Bids received after this time will not be considered. Please note for bid delivery purposes, the hours of operation for LCPW are Monday through Thursday, 6:00 AM to 4:30 PM, MST.

3.2 Delivery of Bids

All bids shall be sealed and delivered or mailed to the address of Laramie County Public Works (faxes and emails will not be accepted).

**KEN GARFF CHEYENNE
2200 WESTLAND RD
CHEYENNE, WY 82001**

3.3 Optional Pre-bid Information

No specific pre-bid meeting will be held. Each respondent shall contact John Poelma 307-633-4690 or john.poelma@laramiecountywy.gov to discuss the bid with the County, if needed.

3.4 Public RFB Opening

Only the names of the vendors submitting bids will be read aloud at the RFB opening. The bids will be available for inspection during normal business hours in the Laramie County Public Works Department within three (3) working days of the closing date, by appointment. Bid opening will occur on **January 4, 2024, at 2:15 PM** at the Laramie County Public Works office. A complete tabulation of bids will be available after it is completed.

Individuals covered by the Americans with Disabilities Act of 1990 in need of accommodations to attend public RFB openings or meetings should contact the Public Works Department in Cheyenne at (307) 633-4690 at least five (5) days prior to the date.

3.5 Bid Form

- A. See Submittal Requirements for complete details.
- B. Each respondent shall submit THREE (3) complete sets of the bid form, one marked "ORIGINAL" and TWO (2) marked "COPY". The bid shall be submitted on an exact copy of the attached bid form.
- C. The bid form must be signed by an official authorized to legally bind the respondent to all RFB provisions contained herein.
- D. Terms and conditions differing from those in this RFB may be cause for disqualification of the bid.

3.6 Questions Concerning RFB

Questions concerning any portion of this RFB should be directed in writing to John Poelma, Public Works Department, named below, who shall be the official point of contact for this RFB. Mark cover page or envelope(s) "**Class 5 truck with Service Body**".

Submit questions to:

John Poelma
Deputy Director
Public Works
(307) 633-4302

John.Poelma@laramiecountywy.gov

3.7 Clarification and Addenda

It is incumbent upon each respondent to carefully examine all specifications, terms, and conditions contained herein. Any inquiries, suggestions, or requests concerning interpretation, clarification or additional information shall be made in writing, (facsimile transmissions

acceptable) through the Assistant Director named above. The County will not be responsible for any oral representation(s) given by any employee, representative or others. The issuance of a written addendum is the only official method by which interpretation, clarification or additional information can be given.

If it becomes necessary to revise or amend any part of this RFB, notice may be obtained by accessing the Laramie County web site. Respondents in their bid must acknowledge receipts of amendments. **Each respondent should ensure that they have received all addenda and amendments to this RFB before submitting their bid. Please check the Laramie County web site at <http://www.laramiecountywv.gov> for any addenda.**

3.8 Award

The County reserves the right to award the contract to the respondent(s) that the County deems to offer the best overall bid(s). The County is therefore not bound to accept a bid on the basis of lowest price. In addition, the County at its sole discretion, reserves the right to cancel this RFB, to modify the quantities of product we purchase, to reject any and all bids, to waive any and all informalities and/or irregularities, or to re-advertise with either the identical or revised specifications, if it is deemed to be in the best interest of the County to do so. The County also reserves the right to make multiple awards, based on experience and qualifications if it is deemed to be in the County's best interest.

3.9 Contract

The contents of this RFB and all provisions of the successful bid deemed pertinent by the County may be incorporated into a contract and become legally binding. A separate contract document will be issued.

The County Commissioners are the sole Contracting Officer for Laramie County, Wyoming, and only he/she or his/her designee is authorized to make changes to any contract. The County shall be responsible for only those orders placed by the County on an authorized signed Purchase Order or Price Agreement. The County shall not be responsible for any order, change, substitution or any other discrepancy from the Purchase Order or Price Agreement. If there is any question about the authenticity of a Purchase Order, Price Agreement or change order, the respondent should promptly contact the Public Works Department at (307) 633-4690.

3.10 Disclosure of RFB Content

All material submitted becomes the property of the County and may be returned only at the County's option. The County has the right to use any or all ideas presented in any reply to this RFB. Selection or rejection of any bid does not affect this right.

3.11 Respondent's Responsibility

A respondent, by submitting a bid represents that:

- A. The respondent has read and understands the RFB in its entirety that and the bid is made in accordance therewith, and
- B. The respondent possesses the capabilities, resources, and personnel necessary to provide efficient and successful service to the County, and;
- C. Before submitting a bid, each respondent shall make all investigations and examinations necessary to ascertain site and/or local conditions and requirements affecting the full performance of the contract and to verify any representations made by Laramie County upon which the respondent will rely. If the respondent receives an award because of its bid submission, failure to have made such investigations and examinations will in no way relieve the respondent from its obligations to comply in every detail with all provisions and requirements of the contract, nor will a plea of ignorance of such conditions and requirements be accepted as a basis for any claim by the respondent for additional compensation or relief.

3.12 Payment Terms

The County will remit full payment on all undisputed invoices within forty-five (45) days from receipt by the appropriate person(s) (to be designated at time of contract) of the invoice(s) or receipt of all products or services ordered.

3.13 Minor Irregularities

The County reserves the right to waive minor irregularities in bids, providing such action is in the best interest of the County. Minor irregularities are defined as those that have no adverse effect on the County's best interests and will not affect the outcome of the selection process by giving the respondent an advantage or benefit not enjoyed by other respondents.

3.14 Deviations

All bids must clearly and with specific detail, note all deviations to the exact requirements imposed upon the respondent by the General Terms & Conditions. Such deviations must be stated upon the Bid Form; otherwise, Laramie County will consider the subject bids as being made in strict compliance with said General Terms & Conditions to respondents; the respondent being held therefore accountable and responsible. Respondents are hereby advised that Laramie County will only consider bids that meet the exact requirements imposed by the General Terms & Conditions; except, however, said bids may not be subject to such rejection where, at the sole discretion of Laramie County, the stated deviation is considered to be equal or better than the imposed requirement and where said deviation does not destroy the competitive character of the RFB process by affecting the amount of the bid such that an advantage or benefit is gained to the detriment of the other respondents.

3.15 Selection Criteria

Each bid shall be evaluated using the following criteria:

1. Proper submittal of ALL documentation as required by this bid
2. Overall scope and quality of the proposed project
3. Meeting or exceeding the requirements of the RFB
4. Quality and compatibility of the work proposed
5. Ability to accomplish project in a timely manner
6. The benefits to Laramie County as it pertains to:
 - a. Related experience in the areas covered in the RFB
 - b. Past record of performance on contracts with government agencies and private industry with respect to such factors as control of costs, quality of work and ability to meet schedules
 - c. Experience, ability, and overall quality of past and current projects

3.16 Termination / Cancellation of Contract

The County reserves the right to cancel the contract without cause with a minimum thirty (30) days written notice. Termination or cancellation of the contract will not relieve the respondent of any obligations for any deliverables entered into prior to the termination of the contract (i.e., reports, materials, statements of accounts, etc., required and not received). Termination or cancellation of the contract will not relieve the respondent of any obligations or liabilities resulting from any acts committed by the respondent prior to the termination of the contract.

3.17 Incurred Expenses

This RFB does not commit Laramie County to award a contract. Nor shall Laramie County be responsible for any cost or expense which may be incurred by the respondent in preparing and submitting the bid called for in this RFB, or any cost or expense incurred by the respondent prior to the execution of a contract agreement.

3.18 Presentations by Respondents

Laramie County, at its sole discretion, may ask individual respondents to make oral presentations and/or demonstrations without charge to the County.

The County reserves the right to require any respondent to demonstrate to the satisfaction of the County that the respondent has the fiscal and managerial abilities to properly furnish the services proposed and required to fulfill the contract. The demonstration must satisfy the County and the County shall be the sole judge of compliance.

Respondents are cautioned not to assume that presentations will be required and should include all pertinent and required information in their original bid package.

3.19 Minimum Specifications

The specifications listed in the Scope of Service are the minimum required performance specifications for this RFB. They are not intended to limit competition nor specify any particular respondent, but to ensure that the County receives quality services.

3.20 Respondent's Personnel

The respondent shall be responsible for ensuring that its employees, agents and subcontractors comply with all applicable laws and regulations and meet all federal, state and local requirements related to their employment and position. The respondent certifies that it does not and will not during the performance of the contract employ illegal alien workers or otherwise violate the provisions of the federal Immigration Reform and Control Act of 1986, as amended. During the performance of the contract, the respondent agrees to the following:

The respondent shall not discriminate against any employee or applicant for employment because of race, religion, color, sex, age, handicap or national origin, except when such condition is a bona fide occupational qualification reasonably necessary for the normal operations of the respondent.

The respondent agrees to post in conspicuous places, visible to employees and applicants for employment, notices setting forth the provisions of this nondiscrimination clause.

The respondent, in all solicitations or advertisements for employees placed by or on behalf of the respondent, shall state that such respondent is an Equal Opportunity Employer.

3.21 Bid Acceptance/Rejection

The County reserves the right to accept or reject any or all bids received as a result of this RFB, or to negotiate separately with competing respondents, and to waive any informalities, defects, or irregularities in any bid, or to accept that bid or bids, which in the judgment of the proper officials, is in the best interest of the County.

4.0 Submittal Requirements

Bids shall include all the information solicited in this RFB, and any additional data that the respondent deems pertinent to the understanding and evaluating of the bid. Bids shall be organized, and sections tabbed in the following order. The respondent should not withhold any information from the written response in anticipation of presenting the information orally or in a demonstration, since oral presentations or demonstrations may not be solicited. All bids shall include at minimum:

Tab 1 – Respondent’s Profile

A brief profile of the firm, including the firm’s overall qualifications to provide services necessary to fulfill all requirements outlined in the project Scope of Work.

Tab 2 - Completed Bid Form (use attached form)

Tab 3 – References

List at least three (3) recent references where the equivalent project(s) have been conducted within the past five years.

Tab 4 – Other Information

Include any additional information you believe will assist the County in the selection process of qualified respondents. Please be succinct.

5.0 Disclosures

The laws of Wyoming require that the contents of all bids shall be placed in the public domain and be open to inspection by interested parties. Trade secrets or proprietary information that are recognized as such and are protected by law may be withheld if clearly identified as such in the bid. The entire bid cannot be designated as proprietary or a trade secret. If a request is received to examine portions designated as proprietary or a trade secret, Laramie County will notify the vendor to permit the vendor to defend the proprietary nature of the information.

If a respondent discovers any ambiguity, conflict, discrepancy, exclusionary specifications, omission, or other error in this document, the respondent shall immediately notify the issuing office. If the respondent is awarded a contract, then such respondent will not be entitled to additional compensation, relief, or time by reason of the error or its later correction.

The successful respondent will be expected to enter into a contract with Laramie County upon terms acceptable to the County. Respondent will be required to be registered in Sam.gov to receive federal ARPA funding as a contractor/vendor to this RFB.

Following the award of the contract, responses to this bid are subject to release as public information unless specific parts of the response can be shown to be exempt from the laws of the State of Wyoming. Respondents are advised to consult with their legal counsel regarding disclosure issues and take the appropriate precautions to safeguard trade secrets or any other proprietary information. Laramie County assumes no obligation or responsibility for asserting legal arguments on behalf of potential respondents.

If a respondent believes that parts of a bid are confidential then the respondent must so specify. The respondent must mark in bold red letters the term “CONFIDENTIAL” on that part of the response, which the respondent believes to be confidential. The respondent must submit in

**KEN GARFF CHEYENNE
2200 WESTLAND RD
CHEYENNE, WY 82001**

writing specific detailed reasons, including any relevant legal authority, stating why the respondent believes the material to be confidential. Vague and general claims as to confidentiality will not be accepted. Laramie County will be the sole judge as to whether a claim is general and/or vague in nature. All parts of bids, which are not marked as confidential, will be automatically considered public information after the contract is awarded. The successful bid may be considered public information even though parts are marked confidential.

Bids must be signed by a person authorized to commit the respondent to provide the services requested in this RFB. Submission of a signed bid will be interpreted to mean the respondent has agreed to all terms and conditions set forth in all of the sheets which make up this RFB.

Laramie County accepts no obligations for the costs incurred in responding to this RFB in anticipation of being awarded a contract. Laramie County reserves the right to reject any and all submitted bids. It is understood that all bids become the property of Laramie County and will be available for public inspection. No obligation is made by retention of these bids, nor is Laramie County committed to awarding a contract as a result of this RFB.

Each respondent must disclose any existing or potential conflict of interest relative to the performance of the requirements of this bid. Examples of potential conflicts may include an existing business or personal relationship between the respondent, its principal or any affiliate or subcontractor, with Laramie County or any other entity or person involved in any way in the project that is the subject of this RFB. Similarly, any personal or business relationship between the respondent, the principals, or an affiliate or subcontractor, with any employee of Laramie County or its suppliers must be disclosed. Any such relationship that might be perceived or represented as a conflict should be disclosed. Failure to disclose any such relationship or reveal personal relationships with Laramie County employees may be cause for contract termination. Laramie County will decide if an actual or perceived conflict should result in bid disqualification. By submitting a response to this RFB, all respondents affirm that they have not given, nor intend to give, any time hereafter any economic opportunity, future employment, gift, loan, gratuity, special discount, tip, favor, or service to a Laramie County employee or representative in connection with the procurement.

Governmental Immunity

Laramie County does not waive its Governmental/Sovereign Immunity, as provided by any applicable law including W.S. 1-39-101 et seq., by issuing this RFB or by entering into any subsequent agreement. Further, Laramie County fully retains all immunities and defenses provided by law with regard to any action, whether in tort, contract or any other theory of law, based on this RFB or any subsequent agreement.

Indemnification

To the fullest extent permitted by law, the successful respondent agrees to indemnify and hold harmless Laramie County, its appointed officials, elected officials, employees and volunteers from any and all liability for injuries, damages, claims, penalties, actions, demands or expenses

KEN GARPT CHEYENNE
2200 WESTLAND RD
CHEYENNE, WY 82001

arising from or in connection with any work performed by or on behalf of respondent for Laramie County pursuant to any agreement with Laramie County.

Termination

The selection may be terminated (a) by either party at any time for failure of the other party to comply with the terms and conditions of the RFB or any subsequent agreement; (b) by either party, with thirty days' prior written notice to the other party; or (c) upon mutual written agreement by both parties.

Force Majeure

Neither the respondent nor Laramie County shall be liable to perform under this RFB or subsequent agreement if such failure arises out of causes beyond control, and without the fault or the negligence of said party. Such causes may include, but are not restricted to, Act of God or the public enemy, fires, floods, epidemics, quarantine restrictions, freight embargoes and unusually severe weather. In every case, however, a failure to perform must be beyond the control and without the fault or the negligence of said party.

The submission of a bid shall be considered acceptance to all the terms and conditions provided herein and in the various bid documents, unless specifically noted otherwise in the bid.

[REMAINDER OF PAGE LEFT INTENTIONALLY BLANK]

KEN GARFF CHEYENNE
2200 WESTLAND RD
CHEYENNE, WY 82001

6.0 BID FORM (Attachment)

TO: John Poelma
13797 Prairie Center Circle
Cheyenne, WY 82009
(307) 633-4302

The undersigned hereby declares that [firm name] KGA-Chey, LLC

have carefully examined the specifications to furnish: **One (1) new Class 5 Truck with Service Body** for which bids were advertised to be received no later than 2:00 PM, MST, January 4, 2024 and further declare that [firm name]

KGA Chey, LLC will furnish the said work according to specifications.

Proposed Cost Total Estimated Cost for Project: \$ \$15,7809.00

The above prices are all inclusive; County shall pay no other forms of compensation. The County reserves the right to add additional related services that were not known at the time of the publishing of this RFB to any resulting contract, upon negotiations with awarded contractors that is mutually agreeable.

Have you supplied the Submittal Requirements outlined above? YES NO

Laramie County reserves the right to reject any or all bids, to waive informalities, and to accept all or any part of any bid as they may deem to be in the best interest of the County.

I hereby certify that I have read and understand the requirements of this Request for Bids and, that I as the respondent, will comply with all requirements, and that I am duly authorized to execute this bid/offer document and any contract(s) and/or other transactions required by award of this RFB.

Company KGA-Chey LLC

By Ron Downey (Print name)

Signature 

Address 2200 Westland Rd

City Cheyenne State WY ZIP 82001

Telephone 307-638-3335 Fax 307-773-0325

E-Mail Address: rdowney@kengarff.com

DUNS# 010613461

KEN GARFF CHEYENNE
2200 WESTLAND RD
CHEYENNE, WY 82001



Preview Order U300 - X5H 4x4 Super Chas Cab DRW: Order Summary Time of Preview: 01/04/2024 10:45:53 Receipt: NA

Dealership Name: Ken Garff Ford Cheyenne

Sales Code : F56422

| | | | | | | | |
|---------------|---------------|---------------|-------|--------------|-----------|-------------|------|
| Dealer Rep. | RONALD DOWNEY | Type | Fleet | Vehicle Line | Superduty | Order Code | U300 |
| Customer Name | Laramie Co. | Priority Code | B1 | Model Year | 2024 | Price Level | 425 |

| DESCRIPTION | MSRP | DESCRIPTION | MSRP |
|--------------------------------|---------|--------------------------------|--------|
| F550 4X4 SUPERCAB CHAS CAB/168 | \$59130 | ENGINE BLOCK HEATER | \$190 |
| 168 INCH WHEELBASE | \$0 | 50 STATE EMISSIONS | \$0 |
| TOTAL BASE VEHICLE | \$59130 | HIGH CAPACITY TRAILER TOW PKG | \$580 |
| OXFORD WHITE | \$0 | 40 GAL AFT OF AXLE FUEL TNK | \$0 |
| CLOTH 40/20/40 SEAT | \$100 | PAYLOAD PLUS PACKAGE UPGRADE | \$1155 |
| MEDIUM DARK SLATE | \$0 | PRICE CONCESSION INDICATOR | \$0 |
| PREFERRED EQUIPMENT PKG.660A | \$0 | REMARKS TRAILER | \$0 |
| .XL TRIM | \$0 | DUAL BATTERY | \$0 |
| .AIR CONDITIONING -- CFC FREE | \$0 | REAR VIEW CAMERA & PREP KIT | \$415 |
| .AM/FM STEREO MP3/CLK | \$0 | SPECIAL DEALER ACCOUNT ADJUSTM | \$0 |
| 6.7L POWER STROKE V8 DIESEL | \$9995 | SPECIAL FLEET ACCOUNT CREDIT | \$0 |
| 10-SPEED AUTO TORQSHIFT | \$0 | FUEL CHARGE | \$0 |
| 225/70R19.5G BSW ALL POSITION | \$0 | NET INVOICE FLEET OPTION (B4A) | \$0 |
| 4.30 RATIO LIMITED SLIP AXLE | \$395 | PRICED DORA | \$0 |
| JOB #2 ORDER | \$0 | ADVERTISING ASSESSMENT | \$0 |
| FORD FLEET SPECIAL ADJUSTMENT | \$0 | DESTINATION & DELIVERY | \$1995 |
| 19500# GVWR PACKAGE | \$0 | | |

TOTAL BASE AND OPTIONS
 DISCOUNTS
 TOTAL

MSRP
 \$73955
 NA
 \$73955

To LC with upfit

\$157,809.00

ORDERING FIN: QE109 END USER FIN: QE109

INCENTIVES

Acc. Code ID :10 Contract/Ref # :21-170R Bid Date :07/24/23State : WY

DISCOUNTS:
\$-100.00

Customer Name:
Customer Address:

Customer Email:
Customer Phone:

Customer Signature

Date

This order has not been submitted to the order bank.

This is not an invoice.

KEN GARFF CHEYENNE
2200 WESTLAND RD
CHEYENNE WY 82001



PO BOX 2888
 Casper, WY 82601
 Kevin Balster
 (307) 262-6028
 (307) 262-6028 Mobile
 kevin@307atec.com

| | | | | |
|-------|----------------------------------------------|-------------------------------------------------------------------------------------------------------------------------------------------------------------------------------------------------------------------------------------------------------------------------------------------------------------------------------------------------------------------------------------------------------------------------------------------------------------------------|------------|-------------|
| | | -Mounting Plate, Welder: Installed on compt top; Distributor to verify location at time of order; Welder NOT included; For A Miller bobcat 260 welder. | | |
| 6.00 | LED WORK LIGHT | Square; Pedestal Mount; Polycarbonate Lens; Black Powder Coated Die Cast Aluminum Housing; Stainless Steel Bracket; 1100 Raw Lumens; 9- 32 Volts | \$500.00 | \$492.30 |
| | | Capacity 6,000 lbs (2,721 kg) at 6.0 ft (1.83 m) Rating 36,000 ft-lb (4,981-m) Length 20.5 ft (6.25 m) fully extended Weight 1,455 lb (660 kg) Chassis Class 4 (14,500 GVWR minimum) Body Titan 38, Titan 50, Titan 60 Stowed Boom Length 10' 4" (3.96 m) Extended Boom Length 20' 4" (6.2 m) | | |
| 1.00 | HC-6 NEXSTAR 4 WIRELESS | Width 1' 11¼" (.59 m) Height 2' 11¼" (.90 m) Base Plate Dimensions 16.75" x 16.75" (0.43 m x 0.43 m) Single Line Speed 60 ft/min (18.3 m/min) Boom Down 11-15 seconds (full stroke of cylinder) Boom Retract 10-14 seconds (full stroke of cylinder) Hydraulic Requirements 8 gpm (30 L/min) at 2,750 psi.(190 bar) Cable 80 ft (24.38 m) of 5/16" (8 mm) aircraft quality cable Standards OSHA 1910.180 ANSI B30.5 Warranty 2 year warranty | \$2,250.00 | \$33,848.00 |
| 1.00 | MISC HYD HOSES & FITTINGS | PTO, tank & HYD HOSES & FITTINGS | \$625.00 | \$4,046.00 |
| 1.00 | MISC HYD HOSES & FITTINGS | MISC HYD HOSES & FITTINGS | \$0.00 | \$800.00 |
| 1.00 | 15 INCH OCTAGONAL LED MINI LIGHT BAR - AMBER | 15 Inch Octagonal LED Mini Light Bar - Amber | \$125.00 | \$186.00 |
| 1.00 | DRILL FREE LIGHT BAR CAB MOUNT | Drill-Free Light Bar Cab Mount For Chevy/GMC 1500-3500 Work Truck Cab (2020) | \$125.00 | \$290.00 |
| 1.00 | GO POWER/POWER INVERTER | Inverts 10.7 Volt DC To 110 Volt AC; Sine Wave Inverter; 2000 Watts Output/ 4000 Watts Surge; 85 To 92 Percent Efficiency; Two GFIC And HW Outlet; With GP-ISWR-12 Remote; Thermostatically Controlled Fan; 8.2 Inch Width x 6.5 Inch Height x 16.6 Inch Length; GP-ISW2000-12 | \$250.00 | \$1,078.43 |
| 1.00 | INVERTER FUSE & CABLE KIT | | \$0.00 | \$490.88 |
| 40.00 | SHOP SUPPLIES | Shop Supplies Include But Are Not Limited To: Installation Hardware, Steel, Miscellaneous Electrical, Hydraulic Products, Oils, Lubes, Waste Disposal And Paint Products. | \$0.00 | \$400.00 |
| 1.00 | SPRAYLINE SUBLET CASPER | Spray line the bed and tailgate | \$0.00 | \$850.00 |

Totals

Total Parts Price \$31,174.61
 Total Labor Price \$5,125.00



PO BOX 2888
 Casper, WY 82601
 Kevin Balster
 (307) 262-6028
 (307) 262-6028 Mobile
 kevin@307atec.com

| | | | |
|--------------|-----------------------------------------------------------|-----------------|--------------------------|
| Bill To Name | Ken Garff Cheyenne | Quote Number | 00013637 |
| Bill To | 2200 Westland Road Cheyenne, WY 82001 United States | Order Number | 2558 |
| Ship To | 2200 WESTLAND ROAD CHEYENNE, WY 82001 United States | Created Date | 12/12/2023 |
| | | Contact Name | David Sutherland |
| | | Phone | 307-773-0388 |
| | | Email | dsutherland@kengarff.com |
| | | Expiration Date | 12/29/2023 |

| VIN | Year | Make | Model | Fuel Type | Cab Configuration | Wheel | Cab to Axle |
|-----|------|------|-------|-----------|-------------------|-------|-------------|
| 1 | 2024 | Ford | F550 | Diesel | Extended | Dual | 60.00 |

| Quantity | Product | Custom Description | Labor Price | Parts Price |
|----------|-------------------------|-----------------------------------------------------------------------------------------------------------------------------------------------------------------------------------------------------------------------------------------------------------------------------------------------------------------------------------------------------------------------------------------------------------------------------------------------------------------------------------------------------------------------------------------------------------------------------------------------------------------------------------------------------------------------------------------------------------------------------------------------------------------------------------------------------------------------------------------------------------------------------------------------------------------------------------------------------------------------------------------------------------------------------------------------------------------------------------------------------------------------------------------------------------------------------------------------------------------------------------------------------------------------------------------------------------------------------------------------------------------------------------------------------------------------------------------------------------------------------------------------------------------------------------------------------------------------------------------------------------------------------------------------------------------------------------------------------------------------------------------------------------------------------------------------------------------------------------------------------------------------------------|-------------|-------------|
| 1.00 | 6108DL-44 CRANE BODY | 6108dl-44 Crane Body: -Overall Length: 109-1/4" -Overall Width: 94" -Floor Width: 50" -Side Compartment Height: 44" -Side Compartment Depth: 22" -Floor Height: 24" -Streetside Compartmentation: 1V = 36-1/2" in length x 44" high; H = 48" in length x 22-1/2" high; 2V = 24-3/4" in length x 44" high. -Curbside Compartmentation: 1V = 36-1/2" in length x 44" high; H = 47-1/2" in length x 22-1/2" high; 2V = 25-1/4" in length x 44" high. -Standard Shelving: No standard shelving provided All vertical compartments include shelf clips for use with optional shelving. Horizontal compartments have provisions for optional bolt-in divider shelves. -Warranty: Standard Knapheide Limited Warranty -Paint Knap White 108J: Interior and Exterior of body painted Knapheide white. Some touch up may be required by distributor after shipment and handling. -DL Series Bumper w/Hitch: w/ Outrigger Receiver Tube, Installed. -KnapLine Bumper -LED Compartment Lights: Shipped Loose -D-Ring Tie Down Flush: 2 D-ring tie downs for a total of (6) *STREETSIDE (Left):* -Ctech 7 Drawer Unit L1V: 30.25w x 34.82h x 19.5d; Fire Engine Red; 3-3" Drawers; 3-5" Drawers; 1-7" Drawer -Ctech 3 drawer Unit LH: 43w x 14.82h x 19.5d; Fire Engine Red; 2-3" Drawers; 1-5" Drawer -Ctech 7 drawer Unit L1V: 17w x 34.82h x 19.5d; Fire Engine Red; 3-3" Drawers; 3-5" Drawers; 1-7" Drawer *CURBSIDE (Right):* -DL Autocrane Crane Plate: EC 6 auto crane -Bottle Gas Retainr R1V SP: Bottle gas retainer should not be used in an enclosed area containing spark producing components. -Adjustable Shelf: RH **Price Includes the Following Options: -Outrigger, hyd OUT/HYD do: STELLAR - 11989S -Kit mtg 60CA ford 17 DL/R: Installation Kit, 2017 & Newer Ford F450/550 60" CA - Loose | \$1,250.00 | \$38,693.00 |



PO BOX 2888
 Casper, WY 82601
 Kevin Balster
 (307) 262-6028
 (307) 262-6028 Mobile
 kevin@307atec.com

Bill To Name Ken Garff Cheyenne
 Bill To 2200 Westland Road
 Cheyenne, WY 82001
 United States
 Ship To 2200 WESTLAND ROAD
 CHEYENNE, WY 82001
 United States

Quote Number 00013637
 Order Number 2558
 Created Date 12/12/2023
 Contact Name David Sutherland
 Phone 307-773-0388
 Email dsutherland@kengarff.com
 Expiration Date 12/29/2023

| VIN | Year | Make | Model | Fuel Type | Cab Configuration | Wheel | Cab to Axle |
|-----|------|------|-------|-----------|-------------------|-------|-------------|
| 1 | 2024 | Ford | F550 | Diesel | Extended | Dual | 60.00 |

| Quantity | Product | Custom Description | Labor Price | Parts Price |
|----------|-------------------------|-------------------------------------------------------------------------------------------------------------------------------------------------------------------------------------------------------------------------------------------------------------------------------------------------------------------------------------------------------------------------------------------------------------------------------------------------------------------------------------------------------------------------------------------------------------------------------------------------------------------------------------------------------------------------------------------------------------------------------------------------------------------------------------------------------------------------------------------------------------------------------------------------------------------------------------------------------------------------------------------------------------------------------------------------------------------------------------------------------------------------------------------------------------------------------------------------------------------------------------------------------------------------------------------------------------------------------------------------------------------------------------------------------------------------------------------------------------------------------------------------------------------------------------------------------------------------------------------------------------------------------------------------------------------------------------------------------------------------------------------------------------------------------------------------------------------------------------------------------------------------------------|-------------|-------------|
| 1.00 | 6108DL-44 CRANE BODY | 6108dl-44 Crane Body: -Overall Length: 109-1/4" -Overall Width: 94" -Floor Width: 50" -Side Compartment Height: 44" -Side Compartment Depth: 22" -Floor Height: 24" -Streetside Compartmentation: 1V = 36-1/2" in length x 44" high; H = 48" in length x 22-1/2" high; 2V = 24-3/4" in length x 44" high. -Curbside Compartmentation: 1V = 36-1/2" in length x 44" high; H = 47-1/2" in length x 22-1/2" high; 2V = 25-1/4" in length x 44" high. -Standard Shelving: No standard shelving provided All vertical compartments include shelf clips for use with optional shelving. Horizontal compartments have provisions for optional bolt-in divider shelves. -Warranty: Standard Knapheide Limited Warranty -Paint Knap White 108J: Interior and Exterior of body painted Knapheide white. Some touch up may be required by distributor after shipment and handling. -DL Series Bumper w/Hitch: w/ Outtrigger Receiver Tube, Installed. -KnapLine Bumper -LED Compartment Lights: Shipped Loose -D-Ring Tie Down Flush: 2 D-ring tie downs for a total of (6) *STREETSIDE (Left):* -Ctech 7 Drawer Unit L1V: 30.25w x 34.82h x 19.5d; Fire Engine Red; 3-3" Drawers; 3-5" Drawers; 1-7" Drawer -Ctech 3 drawer Unit LH: 43w x 14.82h x 19.5d; Fire Engine Red; 2-3" Drawers; 1-5" Drawer -Ctech 7 drawer Unit L1V: 17w x 34.82h x 19.5d; Fire Engine Red; 3-3" Drawers; 3-5" Drawers; 1-7" Drawer *CURBSIDE (Right):* -DL Autocrane Crane Plate: EC 6 auto crane -Bottle Gas Retainr R1V SP: Bottle gas retainer should not be used in an enclosed area containing spark producing components. -Adjustable Shelf: RH **Price Includes the Following Options: -Outtrigger, hyd OUT/HYD do: STELLAR - 11989S -Kit mtg 60CA ford 17 DL/R: Installation Kit, 2017 & Newer Ford F450/550 60" CA - Loose | \$1,250.00 | \$38,693.00 |



PO BOX 2888
 Casper, WY 82601
 Kevin Balster
 (307) 262-6028
 (307) 262-6028 Mobile
 kevin@307atec.com

| | | | | |
|-------|----------------------------------------------|-------------------------------------------------------------------------------------------------------------------------------------------------------------------------------------------------------------------------------------------------------------------------------------------------------------------------------------------------------------------------------------------------------------------------------------------------------------------------|------------|-------------|
| | | -Mounting Plate, Welder: Installed on compt top; Distributor to verify location at time of order; Welder NOT included; For A Miller bobcat 260 welder. | | |
| 6.00 | LED WORK LIGHT | Square; Pedestal Mount; Polycarbonate Lens; Black Powder Coated Die Cast Aluminum Housing; Stainless Steel Bracket; 1100 Raw Lumens; 9- 32 Volts | \$500.00 | \$492.30 |
| | | Capacity 6,000 lbs (2,721 kg) at 6.0 ft (1.83 m) Rating 36,000 ft-lb (4,98t-m) Length 20.5 ft (6.25 m) fully extended Weight 1,455 lb (660 kg) Chassis Class 4 (14,500 GVWR minimum) Body Titan 38, Titan 50, Titan 60 Stowed Boom Length 10' 4" (3.96 m) Extended Boom Length 20' 4" (6.2 m) | | |
| 1.00 | HC-6 NEXSTAR 4 WIRELESS | Width 1' 11¼" (.59 m) Height 2' 11¼" (.90 m) Base Plate Dimensions 16.75" x 16.75" (0.43 m x 0.43 m) Single Line Speed 60 ft/min (18.3 m/min) Boom Down 11-15 seconds (full stroke of cylinder) Boom Retract 10-14 seconds (full stroke of cylinder) Hydraulic Requirements 8 gpm (30 L/min) at 2,750 psi (190 bar) Cable 80 ft (24.38 m) of 5/16" (8 mm) aircraft quality cable Standards OSHA 1910.180 ANSI B30.5 Warranty 2 year warranty | \$2,250.00 | \$33,848.00 |
| 1.00 | MISC HYD HOSES & FITTINGS | PTO, tank & HYD HOSES & FITTINGS | \$625.00 | \$4,046.00 |
| 1.00 | MISC HYD HOSES & FITTINGS | MISC HYD HOSES & FITTINGS | \$0.00 | \$800.00 |
| 1.00 | 15 INCH OCTAGONAL LED MINI LIGHT BAR - AMBER | 15 Inch Octagonal LED Mini Light Bar - Amber | \$125.00 | \$186.00 |
| 1.00 | DRILL FREE LIGHT BAR CAB MOUNT | Drill-Free Light Bar Cab Mount For Chevy/GMC 1500-3500 Work Truck Cab (2020) | \$125.00 | \$290.00 |
| 1.00 | GO POWER/POWER INVERTER | Inverts 10.7 Volt DC To 110 Volt AC; Sine Wave Inverter; 2000 Watts Output/ 4000 Watts Surge; 85 To 92 Percent Efficiency; Two GFIC And HW Outlet; With GP-ISWR-12 Remote; Thermostatically Controlled Fan; 8.2 Inch Width x 6.5 Inch Height x 16.6 Inch Length; GP-ISW2000-12 | \$250.00 | \$1,078.43 |
| 1.00 | INVERTER FUSE & CABLE KIT | | \$0.00 | \$490.88 |
| 40.00 | SHOP SUPPLIES | Shop Supplies Include But Are Not Limited To: Installation Hardware, Steel, Miscellaneous Electrical, Hydraulic Products, Oils, Lubes, Waste Disposal And Paint Products. | \$0.00 | \$400.00 |
| 1.00 | SPRAYLINE SUBLET CASPER | Spray line the bed and tailgate | \$0.00 | \$850.00 |

Totals

Total Parts Price \$81,174.61
 Total Labor Price \$5,125.00



PO BOX 2888
Casper, WY 82601
Kevin Balster
(307) 262-6028
(307) 262-6028 Mobile
kevin@307atec.com

| | |
|---------------------|-------------|
| Pre-Tax Quote Total | \$86,299.61 |
| Freight | \$2,555.00 |
| Tax Total | \$0.00 |
| <hr/> | |
| Quote Grand Total | \$88,854.61 |

PO Required

PO Number _____

Quote Acceptance

Signature: _____

Name: _____

Date: _____

Terms & Conditions

- F.O.B Ameritech Equipment Company. Freight charge is estimated at the time of quotation. The charge is subject to change at the time of delivery.
- Modifications to customer order after quotation will be at the customer's expense and will be added to the customer's invoice. Customer will be notified prior to any modifications.
- Fast flash adjustments vary by model and is **Customer Responsibility**.
- Quoted price may not include any applicable F.E.T., sales taxes, and delivery charges, or surcharges from manufacturer.
- Quote price does not include any unforeseen obstructions or modifications.
- Quotation valid until above stated expiration date.
- Terms are due upon receipt unless prior credit arrangements are made at the time of order
- 50% down payment required with special order items, **NON REFUNDABLE**.
- **We only Accept Cash, Check, Visa and MasterCard. A 3% Surcharge on all Credit Card Sales**



PO BOX 2888
Casper, WY 82601
Kevin Balster
(307) 262-6028
(307) 262-6028 Mobile
kevin@307atec.com

| | |
|---------------------|-------------|
| Pre-Tax Quote Total | \$86,299.61 |
| Freight | \$2,555.00 |
| Tax Total | \$0.00 |
| <hr/> | |
| Quote Grand Total | \$88,854.61 |

PO Required

PO Number _____

Quote Acceptance

Signature: _____

Name: _____

Date: _____

Terms & Conditions

- F.O.B Ameritech Equipment Company. Freight charge is estimated at the time of quotation. The charge is subject to change at the time of delivery.
- Modifications to customer order after quotation will be at the customer's expense and will be added to the customer's invoice. Customer will be notified prior to any modifications.
- Fast flash adjustments vary by model and is **Customer Responsibility**.
- Quoted price may not include any applicable F.E.T., sales taxes, and delivery charges, or surcharges from manufacturer.
- Quote price does not include any unforeseen obstructions or modifications.
- Quotation valid until above stated expiration date.
- Terms are due upon receipt unless prior credit arrangements are made at the time of order.
- 50% down payment required with special order items, **NON REFUNDABLE**.
- **We only Accept Cash, Check, Visa and MasterCard. A 3% Surcharge on all Credit Card Sales**



References:

City of Cheyenne:

Bryan Bell
2101 O'Neil Ave
Cheyenne, WY 82001
307-637-6446

State of Wyoming:

Dale Spiess
923 West 19th Street
Cheyenne, WY 82001
307-777-7248

Town of Pine Bluffs:



Kim Patterson
215 Main Street
Pine Bluffs, WY 82082
307-245-3746



CLASS 5 TRUCK WITH SERVICE BODY BID DATE 1/04/2024

To whom it may concern:

The Ken Garff Ford dealership in Cheyenne, formally known as KGA-Chey, LLC. Will guarantee the bid price of the cab-chassis only for the "Class 5 Truck with Service Body" bid. Any additional costs, surcharges, etc., from the upfitters above the current bid price will be passed on to Laramie County and will be the responsibility of Laramie County. Due to market conditions, the Ken Garff Ford in Cheyenne will no longer be able to honor the price if there are any additional charges assessed (from the upfitters) to the build of this vehicle.

Respectfully submitted,

Ron Downey

Commercial Account Manager
Ken Garff Ford- Cheyenne
Commercial Vehicle Center
2200 Westland Rd
Cheyenne, WY 82001



STATE OF WYOMING

CERTIFICATE OF RESIDENCY



Contractor Number: 2063

KGA-CHEY, LLC

HAS BEEN GRANTED RESIDENCY STATUS PURSUANT TO WYOMING STATUTE 16-6-101, AS AMENDED. FIVE PERCENT PREFERENCE SHALL BE ALLOWED WHEN BIDDING ON ANY PUBLIC WORKS CONTRACT FOR A PERIOD OF ONE (1) YEAR FROM THE DATE CERTIFICATION IS GRANTED.
GRANTED THIS 2nd DAY of NOVEMBER TWO THOUSAND AND 23

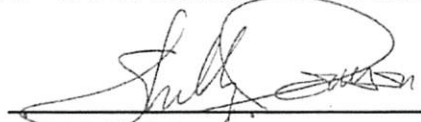

Michele Johnson, Program Manager

EXPIRATION DATE: 11/1/2024



To verify the authenticity of the certificate,
please contact our office at 307-777-7261 or visit
wyomingworkforce.org/businesses/labor/info

CERTIFICATE SERIAL NUMBER: 0211202320

Request for Taxpayer Identification Number and Certification

Give Form to the requester. Do not send to the IRS.

Go to www.irs.gov/FormW9 for instructions and the latest information.

Print or type. See Specific Instructions on page 3.

1 Name (as shown on your income tax return). Name is required on this line; do not leave this line blank.
KGA-CHEY, LLC

2 Business name/disregarded entity name, if different from above
KEN GARFF CHEYENNE

3 Check appropriate box for federal tax classification of the person whose name is entered on line 1. Check only one of the following seven boxes.

Individual/sole proprietor or single-member LLC C Corporation S Corporation Partnership Trust/estate

Limited liability company. Enter the tax classification (C=C corporation, S=S corporation, P=Partnership) ▶ _____

Notes: Check the appropriate box in the line above for the tax classification of the single-member owner. Do not check LLC if the LLC is classified as a single-member LLC that is disregarded from the owner unless the owner of the LLC is another LLC that is not disregarded from the owner for U.S. federal tax purposes. Otherwise, a single-member LLC that is disregarded from the owner should check the appropriate box for the tax classification of its owner.

Other (see instructions) ▶ _____

4 Exemptions (codes apply only to certain entities, not individuals; see instructions on page 3).
Exempt payee code (if any) _____
Exemption from FATCA reporting code (if any) _____
(Applies to accounts maintained outside the U.S.)

5 Address (number, street, and apt. or suite no.) See instructions.
2200 WESTLAND RD

6 City, state, and ZIP code
CHEYENNE, WY 82001

7 List account number(s) here (optional)

Requester's name and address (optional)

Part I Taxpayer Identification Number (TIN)

Enter your TIN in the appropriate box. The TIN provided must match the name given on line 1 to avoid backup withholding. For individuals, this is generally your social security number (SSN). However, for a resident alien, sole proprietor, or disregarded entity, see the instructions for Part I, later. For other entities, it is your employer identification number (EIN). If you do not have a number, see *How to get a TIN*, later.

Note: If the account is in more than one name, see the instructions for line 1. Also see *What Name and Number To Give the Requester* for guidelines on whose number to enter.

Social security number

| | | | | | | | | | | |
|--|--|--|---|--|--|--|---|--|--|--|
| | | | - | | | | - | | | |
|--|--|--|---|--|--|--|---|--|--|--|

OR

Employer identification number

| | | | | | | | | | |
|---|---|---|---|---|---|---|---|---|---|
| 8 | 7 | - | 1 | 1 | 5 | 9 | 8 | 1 | 0 |
|---|---|---|---|---|---|---|---|---|---|

Part II Certification

Under penalties of perjury, I certify that:

- The number shown on this form is my correct taxpayer identification number (or I am waiting for a number to be issued to me); and
- I am not subject to backup withholding because: (a) I am exempt from backup withholding, or (b) I have not been notified by the Internal Revenue Service (IRS) that I am subject to backup withholding as a result of a failure to report all interest or dividends, or (c) the IRS has notified me that I am no longer subject to backup withholding; and
- I am a U.S. citizen or other U.S. person (defined below); and
- The FATCA code(s) entered on this form (if any) indicating that I am exempt from FATCA reporting is correct.

Certification instructions. You must cross out item 2 above if you have been notified by the IRS that you are currently subject to backup withholding because you have failed to report all interest and dividends on your tax return. For real estate transactions, item 2 does not apply. For mortgage interest paid, acquisition or abandonment of secured property, cancellation of debt, contributions to an individual retirement arrangement (IRA), and generally, payments other than interest and dividends, you are not required to sign the certification, but you must provide your correct TIN. See the instructions for Part I, later.

Sign Here Signature of U.S. person ▶ *Bethany J...* Date ▶ 9/30/2021

General Instructions

Section references are to the Internal Revenue Code unless otherwise noted.

Future developments. For the latest information about developments related to Form W-9 and its instructions, such as legislation enacted after they were published, go to www.irs.gov/FormW9.

Purpose of Form

An individual or entity (Form W-9 requester) who is required to file an information return with the IRS must obtain your correct taxpayer identification number (TIN) which may be your social security number (SSN), individual taxpayer identification number (ITIN), adoption taxpayer identification number (ATIN), or employer identification number (EIN), to report on an information return the amount paid to you, or other amount reportable on an information return. Examples of information returns include, but are not limited to, the following:

- Form 1099-INT (interest earned or paid)

- Form 1099-DIV (dividends, including those from stocks or mutual funds)
- Form 1099-MISC (various types of income, prizes, awards, or gross proceeds)
- Form 1099-B (stock or mutual fund sales and certain other transactions by brokers)
- Form 1099-S (proceeds from real estate transactions)
- Form 1099-K (merchant card and third party network transactions)
- Form 1099 (home mortgage interest), 1099-E (student loan interest), 1099-T (tuition)
- Form 1099-C (cancelled debt)
- Form 1099-A (acquisition or abandonment of secured property)

Use Form W-9 only if you are a U.S. person (including a resident alien), to provide your correct TIN.

If you do not return Form W-9 to the requester with a TIN, you might be subject to backup withholding. See *What is backup withholding*, later.

QUICK REFERENCE: WARRANTY COVERAGE

This chart gives a general summary of your warranty coverage provided by Ford Motor Company under the **New Vehicle Limited Warranty**. Please refer to the description of warranty coverage for more specific information.

For each type of coverage, the chart shows two measures:

- years in service
- miles driven



The measure that occurs first determines how long your coverage lasts. For example: Your Bumper to Bumper Coverage lasts for three years - unless you drive more than 36,000 miles before three years elapse. In that case, your coverage ends at 36,000 miles.

For more details on coverage, see:

- **What is Covered?** (pages 9-14)
- **What is Not Covered?** (pages 14-19)

ORIGINAL

**KEN GARFF FORD – CHEYENNE
CLASS 5 TRUCK WITH SERVICE BODY
BID DATE: 01/04/2024 AT 2:00PM**

**KEN GARFF CHEYENNE
2200 WESTLAND RD
CHEYENNE, WY 82001**

Ken Garff Automotive Group

The Ken Garff Automotive Group started in downtown Salt Lake City in 1932. It was established based on the principles of integrity, honesty and personalized customer service. The company has grown over the last 90+ years to include more than 70 dealerships throughout the country. The Ken Garff Automotive Group purchased the Ford dealership in Cheyenne in 2021. The Commercial Vehicle Center at the Ford store in Cheyenne has continued to provide supreme customer service for the commercial and fleet customers' needs throughout Wyoming, western Nebraska and northern Colorado for more than 15 years.

KEN GARFF CHEYENNE
2200 WESTLAND RD
CHEYENNE, WY 82001