



LARAMIE COUNTY PLANNING AND DEVELOPMENT



To: Laramie County Commissioners
From: Justin Arnold, Program Manager, Laramie County Planning and Development
Date: August 2, 2022
Subject: Proposed 2021 Laramie County Land Use Regulations Amendments Notice of Intent

TITLE 1 ADMINISTRATION

CHAPTER 1 GENERAL ADMINISTRATION

1-1-100 STATEMENT OF PURPOSE

The purpose of this regulation is to promote the health, safety, and the general welfare of the citizens of Laramie County. As prescribed by the requirements of Wyoming State Law, these regulations have been designed to implement the goals and vision of the Laramie County Comprehensive Plan. These regulations establish standards of design and procedure for the development and redevelopment of land in Laramie County.

The intent of these regulations is to create a safe and attractive living and working environment; to promote the economic vitality of the County; to further the orderly development of land; to ensure proper legal descriptions and monumenting of subdivided lands; and to minimize the impact of development on land and water resources.

1-1-101 AUTHORITY

These regulations are adopted under the authority granted by Wyoming Statutes; ~~Sections 34-12-101 to 34-12-115 (Platting and Dedication); 18-5-201 to 18-5-207 (Planning and Zoning Commission [County]); 18-5-301 to 18-5-318 and 18-5-401-18-5-405 (Real Estate Subdivisions [County]); 18-5-501 to 18-5-513 (Wind Energy Facilities), 15-1-401 to 15-1-422 (Annexation; Determination of Boundaries; Addition and Exclusion of Land); 15-1-501 to 15-1-512 (Planning); 18-3-701, 24-1-102(b), 24-1-104, and 9-8-401 to 9-8-302 Land Use Planning [State & Local Levels]), as amended. Title 34 Property, Conveyances and Security Transactions, Title 18 Counties, Title 15 Cities and Towns, Title 24 Highways, Title 9 Administration of the Government, Title 35 Public Health and Safety, Title 31 Motor Vehicles, exclusion or absence from this enumerated list of any authority shall not abrogate or otherwise prevent exercise of any authority or enforcement or same, granted to Laramie County by law, regulation or judicial decision or interpretation.~~

1-1-106 COMMUNITY FACILITY FEES AND PUBLIC SAFETY FEES (FIRE PROTECTION)

A. COMMUNITY FACILITY FEES

a. Establishment

Subdividing land in Laramie County requires the assessment of community facility fees. The assessment of fees is made at the time of subdivision permit application submittal, with payment required prior to recordation.

b. Applicable Fees

Fees listed in the following section apply to all subdivisions and replats. Fees shall be assessed for any new lot including those created under W.S. 18-5-306.

c. Classification

All lands platted within Laramie County shall be assessed a community facility fee according to the following schedule:

- i. Land within any water and/or sewer district or serviced by a public water and/ or sewer utility in Laramie County shall be assessed community facility fees at a rate of five hundred dollars (\$500.00) per acre. This fee shall be prorated to the nearest one tenth (0.1) of an acre, but the minimum fee shall not be less than two hundred and fifty dollars (\$250.00).
- ii. Land outside of a water and/or sewer district and land not served by any public water and/or sewer utility in Laramie County shall be assessed community facility fees at a rate of fifty dollars (\$50.00) per acre. The fee shall be prorated to the nearest one tenth (0.1) of an acre, but the minimum fee shall not be less than twenty-five dollars (\$25.00).

d. Exemptions

Lands exempt from community facility fees:

- i. Lands subdivided for governmental use (including schools, parks, offices, greenways, state or county facilities, etc.); and

- ii. Lands subdivided for public streets, roads and alleys; and
- iii. Lands subdivided for public drainage facilities, such as channels, detention or retention pond sites.
- iv. Lands subdivided and designated open space
- v. Where land is being replatted, it shall be exempt if:
 - (A) the replat consists only of reconfiguring or eliminating interior lot lines with no additional land or building area added to the development;
 - (B) the replat results in no additional dwelling units, residential units, nonresidential units or lots, and therefore causes no greater impact on public park or fire facilities than the original plat;

e. Purpose

The use of this fee in Laramie County shall be for fire facilities and equipment for County fire districts and for the construction of County public parks or recreational facilities.

B. PUBLIC SAFETY FEES (FIRE PROTECTION)

a. Establishment

Subdividing land in Laramie County requires the assessment of public safety fees. The assessment of fees is made at the time of subdivision permit application submittal, with payment required prior to recordation.

b. Applicable Fees

Fees listed in the following section apply to all subdivisions and replats. Fees shall be assessed for any new lot including those created under W.S. 18-5-306.

c. Classification

All lands platted within Laramie County shall be assessed a public safety fee according to the following schedule:

- i. Land within any water and/or sewer district or serviced by a public water system shall be assessed a two hundred dollars (\$200.00) per lot public safety fee.

- ii. Land outside of a water and/or sewer district in Laramie County shall be assessed public safety fees at a rate of one thousand dollars (\$1,000.00) per lot.
- iii. Automatic annual adjustment to fee schedule to match national inflations rate not to exceed five percent (5%) as determined by the Consumer Price Index distributed by the Bureau of Labor Statistics.

d. Exemptions

Lands exempt from public safety fees:

- i. Lands subdivided for governmental use (including schools, parks, offices, greenways, state or county facilities, etc.); and
- ii. Lands subdivided for public streets, roads and alleys; and
- iii. Lands subdivided for public drainage facilities, such as channels, detention or retention pond sites.
- iv. Lands subdivided and designated open space
- v. Where land is being replatted, it shall be exempt if:
 - (A) the replat consists only of reconfiguring or eliminating interior lot lines with no additional land or building area added to the development;
 - (B) the replat results in no change in zoning, density, or intensity of the use to the original plat;

e. Purpose

The use of this fee in Laramie County shall be for fire facilities and equipment for County fire districts

C. Public safety fees collected are to be managed by the Laramie County Board of Commissioners and are eligible to be used for the following projects:

- i. Assist land developers in funding the installation of required water cistern for fire protection.

- ii. Assist fire districts in repair, replacement, and maintenance of water cisterns.
- iii. Assist with fire station construction
- f. Rural Water Requirements

The following requirements are to be used to determine if rural water supply or land for a future fire station is required:

<u># OF LOTS</u>	<u>MILES FROM FIRE STATION</u>	<u>MILES FROM EXISTING WATER SUPPLY</u>	<u>DO YOU NEED CISTERN?</u>
-	-	-	-
<u><19</u>	<u><5 ROAD MILES</u>	-	<u>NO CISTERN REQUIRED</u>
<u>>19</u>	<u><5 ROAD MILES</u>	<u><3 ROAD MILES</u>	<u>NO CISTERN REQUIRED</u>
<u>>19</u>	<u>>5 ROAD MILES</u>	<u><3 ROAD MILES</u>	<u>NO CISTERN REQUIRED</u>
<u>>19</u>	<u>>5 ROAD MILES</u>	<u>>3 ROAD MILES</u>	<u>CISTERN REQUIRED</u>
<u>>25</u>	<u>>10 ROAD MILES</u>	<u>>3 ROAD MILES</u>	<u>LAND FOR FUTURE FIRE STATION REQUIRED</u>

* All phases within 5 years equal total units

** Engineered, deeded, platted fire suppression system (sprinkler system) in habitable structures replaces per lot fee and cistern requirement

*** Density, lots smaller than 5 acres and multi-family housing impact this chart and will be handled on individual basis

- g. Inspection and maintenance of static water supply
 - i. Annual inspection of water supply falls upon the fire district having jurisdiction.

ii. Regular maintenance and repair are the responsibility of the fire district having jurisdiction.

iii. Funding of major repairs or replacement of cisterns will be addressed by the board of county commissioners on an individual basis.

h. Approved fire district for water cistern design

30,000-gallon cistern design with direct draft. To be utilized when tank can be installed adjacent to roadway with a dry barrel hydrant featuring two 2.5 male fittings and one large diameter 4.5 fitting. The authority having jurisdiction for fire protection has final approval of location and design of cistern.

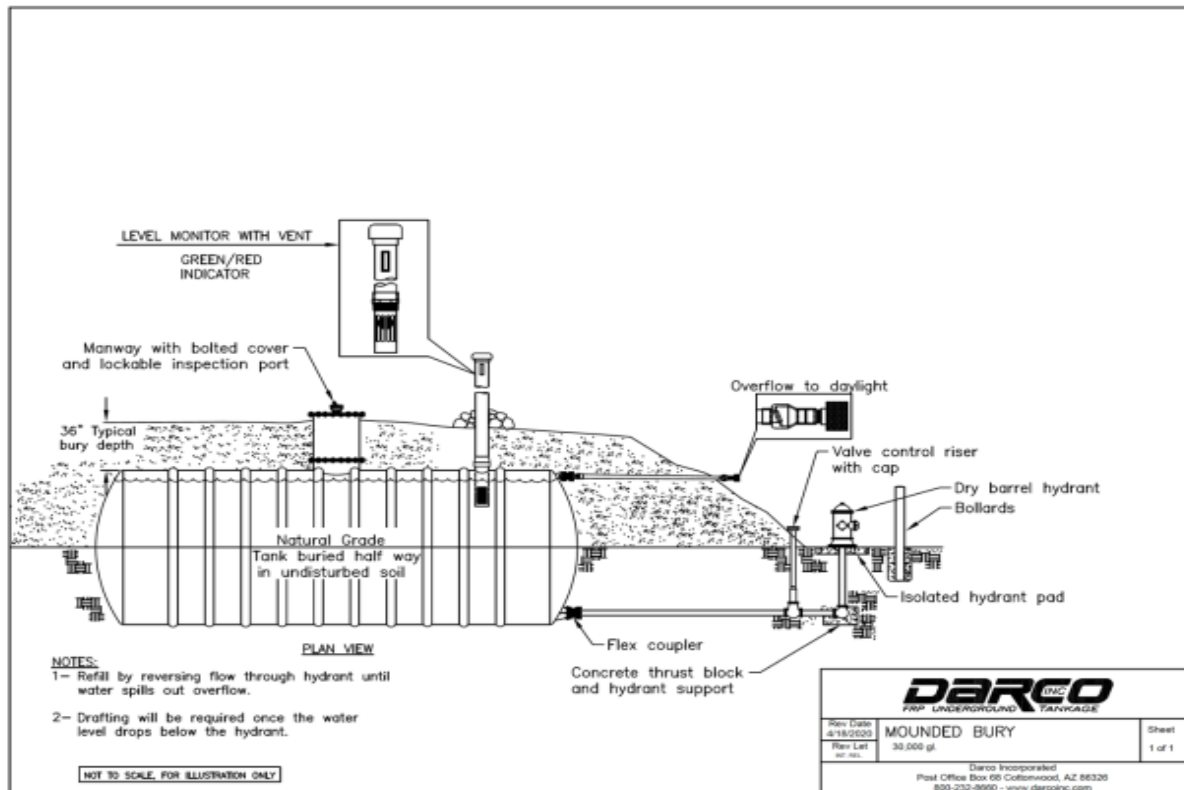

FIRE CISTERN CONCEPT - SUCTION

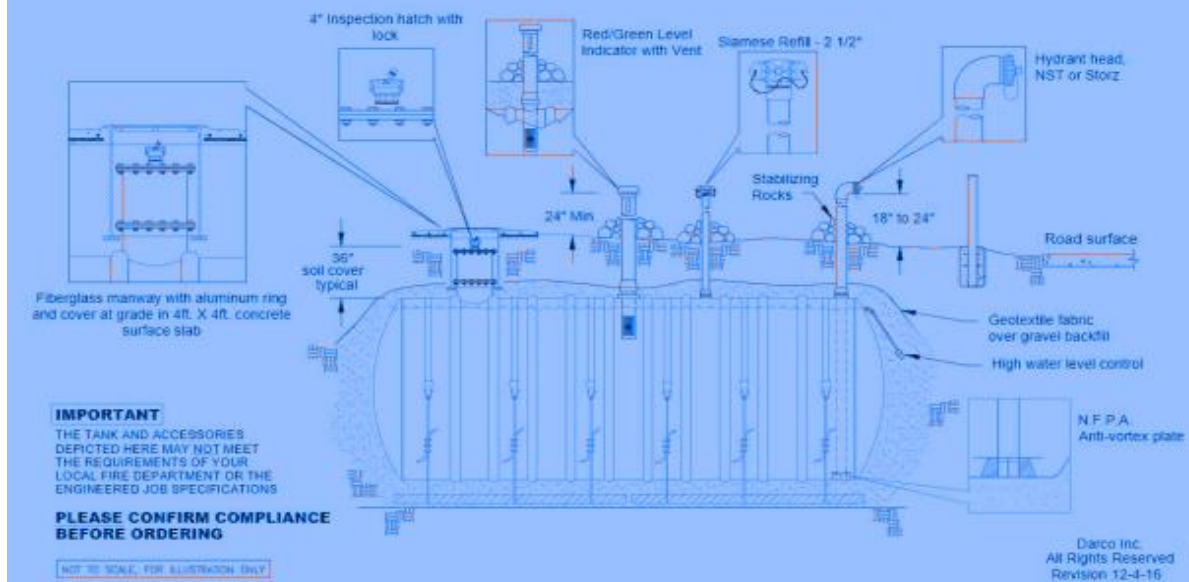

i. Fire station development:

- i. Proposed subdivisions greater than 25 units and further than 10 road miles from an existing fire station:
- ii. Land located in the proposed development to be provided for future fire station (minimum 5 acres)

1-3-101 DEFINITIONS

Food service facilities – any commercial use engaged in the preparation and retail sale of food and beverages for consumption on site.

Temporary Use - A use or activity that is allowed in the district and which is intended to occupy the site on a non-continuous basis, not to exceed 120 days in a calendar year, per site. Sites for temporary laydown yards for road and utility construction may be allowed within the county in all zones and areas for the length of the construction period.

Controlled-access highway - means every highway, street or roadway in respect to which owners or occupants of abutting lands and other persons have no legal right of access to or from the same except at such points only and in such manner as may be determined by the public authority having jurisdiction over the highway, street or roadway. Wyo. Stat. Ann. § 31-5-102.

2-1-101 SUBDIVISION PERMITS

e. Plat Requirements

- viii. Signature blocks for use by the ~~Chairman of the Planning Commission~~ Planning Office for the Planning Commission, the Chairman of the Board and County Clerk for Laramie County, Wyoming. These blocks shall be placed directly adjacent to the right or bottom border of the plat.

2-1-101-1 ADMINISTRATIVE PLATS

(C) Final Decision

Upon review according to the criteria in this section, and within twenty-one (21) working days of the determination of a complete application, the Director shall take one of the following actions:

- (I) Approve the application; or,
- (II) Deny the application and state the specific reasons for denial, and;
- (III) If the property has been previously platted, defer to the Board of County Commissioners for approval.

2-2-126 SITE ADDRESS ~~REQUIRED~~ AND ROAD NAMING

ROAD NAMING

- a. Road names can be approved on Laramie County public roads and access easements that have been approved by Laramie County staff or the Laramie County Commissioners through the following processes:

- i. Platting
 - ii. Subdivision exemption on processes that are reviewed by county staff
 - iii. State statutes Title 24 process
 - iv. Board approval if the it is an existing easement that affects multiple landowners and/or existing addresses
 - v. Road naming application to be reviewed by county staff if it affects only one landowner for existing accesses
- b. Road naming rules:
- i. Be distinct in nature
 - ii. Start from another named road
 - iii. Not have two intersections with the same names

SITE ADDRESSING

- a. A County site address number shall be assigned upon issuance of a building permit for the ~~any single-family residence or commercial~~ the first permitted single family residence or commercial structure on the site. Addresses may also be assigned to other structures or parcels if necessity can be demonstrated and the structure will not be used for human habitation. Assignment of address for non-residential or non-commercial structures shall be approved by the Director.
- b. Address numbers shall be displayed on the front of the structure as seen from the right-of-way. If the number on the structure is not visible from the right-of- way, or the structure is under construction, the number shall also be displayed on a post, fence, wall or gate at the property line adjacent to the point of access to the structure from the right-of-way.
- c. In condominium or other multi-unit structures, the number shall be displayed at each entrance. However, each complex shall only have one numerical road address with separate building numbers or letters and individual unit numbers or letters.
- d. Numbers shall be a minimum of six (6) inches high and shall be of reflective material.
- e. Any numbers posted in violation of this regulation shall be removed.
- f. A site plan may be required in conformance with these regulations prior to issuance of an address.

2-2-114 HOME OCCUPATIONS

Home occupations are intended to allow limited business activity from the home but shall not alter the character of the neighborhood or create adverse impacts to neighborhood, including significant increases in traffic and on-street parking. Home occupations include, but are not limited to the following: arts and crafts making, tailoring or seamstress services, one or two-person professional offices, music instruction and wholesale/catalogue/internet sales.

~~a. Specific Exclusions~~

~~The following businesses shall not be allowed as home occupations:~~

- ~~i. Body or mechanical repair, including but not limited to any modification, assembly or painting of motor vehicles and repair of internal combustion engines~~
- ~~ii. Beauty salons, nail salons and barber shops~~
- ~~iii. Animal grooming salons (not including mobile facilities) and boarding kennels~~
- ~~iv. Body art establishments/body artists~~
- ~~v. Sale of motor vehicles or trailers where a license from WYDOT or the Laramie County Clerk is required~~

~~b. Requirements~~

~~Home occupations shall be in compliance with the following:~~

- ~~i. There shall be no offensive noise, vibration, smoke, dust, odors, heat or glare noticeable at or beyond the property line.~~
- ~~ii. No exterior storage is permitted.~~
- ~~iii. No more than one (1) employee or co-worker other than the permanent resident(s) can work from the site.~~
- ~~iv. Hours for visitation by clients, customers, vendors or other visitors associated with the home occupation, including deliveries, may be restricted.~~
- ~~v. No more than 25 percent of the gross floor area of the primary structure is used for home occupation purposes.~~
- ~~vi. One sign, not to exceed three (3) square feet in area, shall be allowed per primary structure, pursuant to this regulation.~~

- vii. ~~Home occupations must be conducted in the primary residence. Accessory structures may be used for storage and limited services. The use of an accessory structure for a home occupation shall not alter the residential use or character of the neighborhood.~~

a. **Standards for home occupations within LR, MR, HR and PUD urban zoning districts:**

- i. May use accessory structure.
- ii. No outdoor storage.
- iii. One (1) sign at three (3) square feet or less.
- iv. One person, not a member of the household, may be an employee.
- v. No retail or wholesale sales except by phone, internet or mail.
- vi. No industrial uses as provided by definition within the Laramie County Land Use Regulations.
- vii. No body or mechanical repair shop, beauty salon, nail salon, tattoo parlor, barbershop, animal grooming, sale of motor vehicles or trailers.

b. **Standards for home occupations within AR, A-1 and A-2 zoning districts:**

- i. May use accessory structure.
- ii. May use outdoor storage. It shall be screened with permanent vegetation or fencing at least six (6) feet tall at time of installation.
- iii. One (1) sign at six (6) square feet or less.
- iv. One (1) person, not a member of the household, may be an employee.
- v. No retail or wholesale sales except by phone, internet or mail.
- vi. No industrial uses as provided by definition within the Laramie County Land Use Regulations.
- vii. No body or mechanical repair shop, beauty salon, nail salon, tattoo parlor, barbershop, animal grooming, sale of motor vehicles or trailers.

c. **Standards for LU zoning district:**

- i. May use accessory structure.
- ii. May use outdoor storage. It shall be screened with permanent vegetation or fencing at least six (6) feet tall at time of installation.
- iii. Two (2) people, not members of the household, may be an employee.
- iv. No retail or wholesale sales except by phone, internet or mail.
- v. No industrial uses as provided by definition within the Laramie County Land Use Regulations.

- vi. All necessary licenses and permits shall be obtained from relevant government agencies.

2-1-133 SITE PLANS

a. Purpose

The purpose of this regulation is to protect the health, safety and welfare of Laramie County residents through appropriate design of commercial, public and multi-family residential developments. Laramie County recognizes that flexibility and the use of best practices in site design will support the community vision described in the Laramie County Comprehensive Plan by preserving environmental quality and promoting economic vitality. This regulation applies to all commercial, industrial, public, open space and multi-family residential developments within Laramie County.

b. Exemptions

Property with the following land uses are exempt from site plan requirements:

- iv. Single-family residential
- ii. Duplex residences where no more than one (1) structure is proposed per development.
- v. Agricultural property as defined in this regulation.

c. Site Plans for Governmental Entities

Public land uses, including parks, public facilities and government buildings, shall conform to the standards in this regulation.

d. General Site Plan Requirements

- vi. A site plan is required for all new commercial, industrial, public, and multi-family residential land uses. The Planning and Development Director may waive any submittal requirements for a site plan based on impacts determined at the required pre-application meeting.
- vii. All applications for site plan approval shall be submitted on a form provided by the Planning and Development Office.
- viii. Site plans in the regulatory area of the County shall require that notice be mailed to adjacent property owners via certified mail.
- ix. Site plans will be reviewed and approved or disapproved by the Director. Site plans in the regulatory area of the County may require public hearing before the Board of County Commissioners if the Planning and Development Director determines that the impacts of

the proposed use will significantly impact surrounding properties.

e. Buffering Standards for Urban Area Zoning Districts

When a more intense land use is located adjacent to a less intensive land use, or urban zoning district, buffering is required. This applies to all uses, even within the same zoning district. Buffering includes yard width as well as material installed within the buffer yard. Buffering shall be a minimum of 15 feet wide and consist of either of one of the following:

- a. A 6' tall privacy fence: wood plank, concrete, block or brick.
- b. A 6' high earthen berm with ground cover
- c. A combination of a berm and solid fence at least 6' tall.
- d. One (1) evergreen every 10' the length of the buffer yard, at least 6' tall.
- e. A combination of berm and evergreen trees at least 6' tall. Evergreen shall be a minimum of 4' tall, spaced 10' apart.

~~f. To mitigate impacts of adjacent incompatible uses, buffering is required as shown in the table below:~~

~~g. Remove the table below~~

2015 Land Use Regulations

ZONE DISTRICT	AR	A1	A7	LR	MR	HR	NH	BU	FR	FI	HI	P						
AR	SEE NOTES (1, 2)	SEE NOTES (1, 2)	SEE NOTES (1, 2)	SEE NOTES (1, 2)	SEE NOTES (1, 2)	SEE NOTES (1, 2)	SEE NOTES (1, 2)	SEE NOTES (1, 2)	25	25	25	25						
A1	SEE NOTES (1, 2)	SEE NOTES (1, 2)	SEE NOTES (1, 2)	SEE NOTES (1, 2)	SEE NOTES (1, 2)	SEE NOTES (1, 2)	SEE NOTES (1, 2)	SEE NOTES (1, 2)	25	25	25	25						
A7	SEE NOTES (1, 2)	SEE NOTES (1, 2)	SEE NOTES (1, 2)	SEE NOTES (1, 2)	SEE NOTES (1, 2)	SEE NOTES (1, 2)	SEE NOTES (1, 2)	SEE NOTES (1, 2)	25	25	25	25						
LR	SEE NOTES (1, 2)	SEE NOTES (1, 2)	SEE NOTES (1, 2)	SEE NOTES (1, 2)	SEE NOTES (1, 2)	SEE NOTES (1, 2)	SEE NOTES (1, 2)	SEE NOTES (1, 2)	25	25	25	25						
MR	SEE NOTES (1, 4)	SEE NOTES (1, 4)	SEE NOTES (1, 4)	SEE NOTES (1, 4)	SEE NOTES (1, 4)	SEE NOTES (1, 4)	SEE NOTES (1, 4)	SEE NOTES (1, 4)	7½	7½	7½	7½						
HR	SEE NOTES (1, 2)	SEE NOTES (1, 2)	SEE NOTES (1, 2)	SEE NOTES (1, 2)	SEE NOTES (1, 2)	SEE NOTES (1, 2)	SEE NOTES (1, 2)	SEE NOTES (1, 2)	25	25	25	25						
NH	SEE NOTES (1, 2)	SEE NOTES (1, 2)	SEE NOTES (1, 2)	SEE NOTES (1, 2)	SEE NOTES (1, 2)	SEE NOTES (1, 2)	SEE NOTES (1, 2)	SEE NOTES (1, 2)	25	25	25	25						
BU	SEE NOTES (1, 2)	SEE NOTES (1, 2)	SEE NOTES (1, 2)	SEE NOTES (1, 2)	SEE NOTES (1, 2)	SEE NOTES (1, 2)	SEE NOTES (1, 2)	SEE NOTES (1, 2)	25	25	25	25						
FR	25	25	25	25	25	25	25	25	N/A	N/A	N/A	N/A						
FI	25	25	25	25	25	25	25	25	N/A	N/A	N/A	N/A						
HI	25	25	25	25	25	25	25	25	N/A	N/A	N/A	N/A						
P	25	25	25	25	25	25	25	25	N/A	N/A	N/A	N/A						

NOTE (1): 25' BUFFER REQUIRED BETWEEN NON-RESIDENTIAL USE AND ADJACENT RESIDENTIAL USES IF NON-RESIDENTIAL USE IS ALLOWED IN RESIDENTIAL ZONE DISTRICT.

NOTE (2): NO BUFFER REQUIRED WHENF SAME OR USES ALLOWED IN A ZONE DISTRICT ORF ADJACENT TO ONE ANOTHER.

2-2-129 SIGNS

e. Electronic Message Signs or Centers

i. Electronic message signs or centers that employ static, fade or dissolve transitions that do not have the appearance of moving text or images are permitted in the CB, LI, HI, and NB **and LU** zone districts ~~and in the unzoned regulatory area.~~

...

p. Nonconforming Signs

i. Nonconforming signs shall meet the requirements of Section 2-2-105 of this regulation. Nonconforming freestanding signs that cannot be replaced in conformance with Section 2-2-105 of this regulation, due to the inability of the sign replacement to meet State requirements, shall be allowed to relocate if the following conditions are met:

(A) The sign to be replaced qualifies as a legally nonconforming structure.

(B) The replacement sign does not exceed 300 square feet per side.

(C) The replacement sign will be located on property zoned CB, LI, HI or **LU** ~~in the unzoned regulatory area.~~

(D) The replacement sign meets all other requirements of these regulations.

2-2-134 GENERAL LANDSCAPING REQUIREMENTS

A landscape plan is required as a component of all site plans.

a. Landscape Calculations for all commercial development in Laramie County:

i. Zone Districts – The required internal landscape area for the purposes of determining landscape material requirements shall be defined as the area remaining from the maximum building coverage area as specified in each zone district. For multi-family projects and commercial projects in residential zoned areas the area that needs to be landscaped is 20% of the site.

ii. Unzoned Areas—~~Determination of the internal landscape area for properties in the unzoned portion of the County shall be based on fifty (50) percent of the total area of the proposed building footprint, parking, and impervious surfaces.~~

iii. The following tables shall be used to calculate the landscaping point requirements:

a. Trees. The sum of all Tree points, as defined in Table 2-2-134(a) below, must exceed the required landscape area divided by 500. For the purpose of calculating the Tree Point requirement, utility easements within internal landscape areas, athletic fields, and playgrounds may be subtracted from the required internal landscape area.

Table 2-2-134(a)	Quantity	Point Value
Tree Classification		
County Approved existing mature tree	1	3
New 1.5" Caliper Deciduous Tree		
< 30ft mature canopy	1	2
> 30ft mature canopy	1	1.5
New 1.0" Caliper Deciduous Tree		
< 30ft mature canopy	1	2
> 30ft mature canopy	1	1.5
New 1.5" Caliper Ornamental Tree		
> 30ft mature canopy	1	1.5
New 1.0" Caliper Ornamental Tree		
> 30ft mature canopy	1	1
New Evergreen Tree		
8ft Height	1	2
6ft Height	1	1.5
4ft Height	1	1

c. Groundcover. The sum of all groundcover points, as defined in Table 2-2-134(c) below, must exceed the square footage of the required internal landscape area divided by 1000.

Table 2-2-134 (c)	Quantity	Point Value
Groundcover Classification		
Kentucky Bluegrass Sod	500 sq. ft.	0.5
Seeded Areas, Dryland, Riparian, and Native Species	500 sq. ft.	0.75
Ornamental Grasses (#1 GALLON)	1	0.5
Outdoor/Recreational Structure	1	1
Picnic Tables	1	1
Benches	1	1
Athletic Fields	100 sq. ft.	1.5
Playground with ADA accessibility	100 sq. ft.	1
Permeable Paths	100 sq. ft.	2
Other/As approved by Director	Variable	Variable
Table 2-2-134(b)	Quantity	Point Value
Shrub Classification		
Existing Shrub	1	2
Deciduous Shrub	1	1
Evergreen Shrub	1	1

The following requirements shall apply to landscaping within Laramie County:

- i. The landscape plan should be designed to aid in storm water management, cool impervious surfaces, provide year-round screening, create or preserve open spaces, and provide buffering between the site and surrounding land uses.
- ii. The use of adaptive plant species is required for planting selection.
- iii. A list of approved species is available from the Laramie County Planning and Development Office.
- iv. Landscaping may be completed in phases to match construction phases.
 - (A) Alternatives to the required landscaping may be presented to the Planning and Development Director for review. The Director may approve the proposed alternative landscape plan based on the following criteria:
 - I. The proposed alternative meets or exceeds the intent of this Regulation; and,
 - II. The proposed alternative is well-integrated with the surrounding landscaping and land uses; and,
 - III. The proposed alternative meets the goals of the Laramie County Comprehensive Plan; and,
 - IV. The purpose of the required site plan is to legalize an existing use and the impact or benefits of the landscape plan on the property would be minimal; or,
 - V. Within the LU zone seedling tree rows may be used as an alternative to regular landscaping and must be a Laramie County Conservation District or other design professional approved windbreak design. A minimum of two tree rows on two sides of the site is required.
 - VI. The landscaping as required would prohibit reasonable use of the property.
- v. No display of merchandise, goods, equipment for sale or lease, advertising banners, portable or temporary signs shall be permitted in any landscaped area unless the display is specifically shown in the approved site plan and meet the regulations specified in Section 2-2-129 of the Laramie County

Land Use Regulations.

- vi. Plant materials which exhibit evidence of insects, pests, disease and/or damage shall be removed and replaced with living plant material prior to issuance of the Certificate of Compliance.
- vii. Landscape Plan Requirements – The following information must be shown:
 - (A) Name, address and phone number of the property owner and the developer responsible for the landscape plan.
 - (B) North arrow.
 - (C) Bar scale or other indication of scale.
 - (D) Project data, including total square footage of the property; square footage of building areas; square footage of parking areas and driveways; impervious areas, street frontage areas, total number of parking stalls; and the square footage of landscaped areas.
 - (E) Location of all existing trees and shrubs to remain on site.
 - (F) Land uses, existing subdivisions, and property owners bordering the property.
 - (G) All proposed lawn areas, ground cover, trees, shrubs and other landscape materials shall be identified. Seed mixes for adaptive grasses shall be listed on the landscape plan. Quantities of plants and areas of groundcover material shall be specified, along with installation methods.
 - (H) Locations of automatic, below-grade irrigation systems, low-volume drip systems, system controller, and point of connections. Rain barrels or cisterns shall be shown on the landscape plan.
 - (I) Proposed plant materials shall be shown at approximately mature size on the landscape plan with mature widths, heights, trunk calipers and names shown on a legend.
 - (J) Proposed features including bike racks, benches, fountains, trash receptacles or other amenities.
 - (K) Any features specifically placed for storm water

management.

(L) Legend depicting all existing and proposed landscape materials and other features.

(M) Sight distance triangles for all existing or proposed accesses and approaches. A visual sight distance triangle, free of any structures or landscape elements greater than 2.5 feet in height, shall be maintained at street intersections and driveways.

b. The following requirements shall apply to zoned properties within Laramie County:

i. Landscape Material Requirements

(A) Trees

I. Adaptive species shall be used. A list of approved species is available from the Laramie County Planning and Development Office.

II. A mix of coniferous and deciduous trees shall be used.

(a) A minimum of 25 percent of frontage trees shall be coniferous.

(b) A minimum of 25 percent of internal trees shall be coniferous.

(c) Deciduous trees shall be at least five (5) gallons in size or one (1) inch in caliper.

(d) Coniferous trees shall be a minimum of six (6) feet tall.

III. Larger trees may be planted.

IV. Cottonwood (*Populus deltoides*) and aspen (*Populus tremuloides*) trees shall be allowed only in addition to the required trees.

~~V. Within the residential zoned areas of the County, a minimum of one (1) tree per fifty (50) feet of road frontage is required.~~

VI. Trees may be grouped or clustered to aid in overall growth and health, provided that their placement does not cause drifting snow in roadways.

VII. Frontage trees shall be placed between the building and the road right-of-way, but not more than fifty (50) feet from the property line adjacent to the road right-of-way.

VIII. Trees may be placed anywhere in the internal landscape area, provided that they do not interfere with any drainage, utilities, emergency access, or existing or proposed easements.

IX. Trees shall be irrigated.

(B) Ground Cover

I. A listing of adaptive ground cover materials is available from the Laramie County Planning and Development Office.

(C) Substitutions

I. Up to 50 percent of the required internal trees may be substituted with shrubs at a rate of ten (10) shrubs per required tree or 50 percent of the required shrubs may be substituted with trees at the same rate

~~II. Up to 25 percent of the required frontage trees may be substituted with shrubs at a rate of ten (10) shrubs per required tree.~~

III. One (1) tree per site may be substituted with the following amenities:

(a) A park bench that seats at least two (2) people.

(b) A bicycle rack that holds at least five (5) bicycles.

c. Landscaping requirements for unmanned facilities within Laramie County:

i. A waiver of landscaping requirements may be approved by the Laramie County Planning Director for unmanned facilities ~~in the unzoned area,~~ based upon the following criteria:

(A) The total building or structure footprint does not exceed 15% of the property area and meets the nonresidential setbacks outlined in Section 4-1-104; an

(B) The structure is not within 1,000 feet of residential structures, ~~whether zoned or unzoned,~~ and not viewable from a collector or arterial street; or,

(C) Screening/buffering of the unmanned facilities is proposed with a method permitted within Laramie County through these regulations.

ii. Landscaping requirements shall be waived for unmanned Utility and Wireless Telecommunication Services Site Plans for properties that have received Board Approval of the use through the Board of County Commissioners public hearing process.

- a. Small Wind Energy Systems are allowed on any property in unincorporated Laramie County and shall require a building permit. Systems that will not be connected to the power grid may be exempted from permitting by the Chief Building Official. Systems with no grid connections are exempt from building permits.

3-2-103 GESC PERMIT APPLICATION PROCESS

A GESC permit may be required prior to the beginning of construction activities that disturb the land surface as outlined in this regulation.

- a. The applicant for a Low Impact (less than ~~4~~5 acres) GESC permit shall submit to the County the following:

- i. Documentation from the developing party(ies) with the required building permit, to include the following:

- (A) Location map/plan showing proposed BMPs.
- (B) Proposed activities.
- (C) Project size.
- (D) Area to be disturbed, relevant timelines, and final stabilization.
- (E) Photographs/aerial view showing existing conditions of the area to be disturbed (prior to proposed activities).

The County shall review the information provided with the building permit to determine if a Low Impact GESC permit is required. An application that is less than 5 acres but is contained within an area where topography may potentially cause increased impacts to surrounding properties, water features or drainages may be subject to the Standard GESC permit provisions if deemed necessary by the County.

- b. The applicant for a Standard GESC permit shall submit to the County the following:

- i. For disturbance of ~~one (1) to~~ five (5) acres or more –
one copy of the Storm Water Pollution Prevention Plan (SWPPP);

OR AND

- ii. ~~For five (5) or more acres of disturbance~~ - one copy (Signed) of the applicable WYPDES Permit (See Wyoming Department of Environmental Quality website for current information);

AND

~~iii. One copy of the initial Storm Water Pollution Prevention Plan (SWPPP). Minimum requirements for the required SWPPP are as outlined by the WYDEQ associated with the WYPDES permit.~~

TITLE 4 ZONING

4-1-102 DESCRIPTION OF ZONED AREA

~~The specific zoned area where the specific zone district regulations are effective is as follows:~~

- ~~a. — North: One mile north of the township line between Townships 14 and 15 North.~~
- ~~b. — West: One mile east of the range line between Ranges 67 and 68 West.~~
- ~~c. — South: Township line between Townships 12 and 13 North.~~
- ~~d. — East: Three miles east of the range line between Ranges 65 and 66 West, and including that portion of Section 27, T.14N., R.65W. lying south of the Interstate 80 right-of-way.~~

The specific zone district regulations are effective in the entirety of Laramie County, excluding the incorporated cities and towns.

4-1-104 ZONE DISTRICT SETBACK TABLE

	RESIDENTIAL FRONT (PRIMARY)	RESIDENTIAL SIDE (OR SECONDARY FRONT) *	RESIDENTIAL REAR	NON-RESIDENTIAL FRONT (PRIMARY)	NON-RESIDENTIAL SIDE (OR SECONDARY FRONT) *	NON-RESIDENTIAL REAR	OUTDOOR DISPLAY	OUTDOOR STORAGE
AR - AGRICULTURAL RESIDENTIAL	25	15	15	25	25	25	25	25
A1 - AGRICULTURAL & RURAL RESIDENTIAL	25	25	25	25	25	25	25	25
A2 - AGRICULTURAL	25	25	25	25	25	25	25	25
LU - LAND USE	25	15	15	25	25	25	25	25
LR - LOW DENSITY RESIDENTIAL	25	7.5 (10 ST)	20	25	15	20	N/A	N/A
MR - MEDIUM DENSITY RESIDENTIAL	20	5 (10 ST)	20	20	15	20	N/A	N/A
HR - HIGH DENSITY RESIDENTIAL	20 (+5 PER STORY ABOVE 3)	ST)(+5 PER STORY ABOVE 2)	20	20 (+5 PER STORY ABOVE 3)	15	20	N/A	N/A
NB - NEIGHBORHOOD BUSINESS	25	5 (25 ST)	20 (25 ST)	25	5 (25 ST)	5 (25 ST)	15 (ALL)	25 (ALL)
CB - COMMUNITY BUSINESS	25 ADJ ST	5 (25 ST)	20 (25 ST)	25 ADJ ST	5 (25 ST)	5 (25 ST)	15 (ALL)	25 (ALL)
LI - LIGHT INDUSTRIAL	N/A	N/A	N/A	25 ADJ ST	25 ADJ ST & ALL ZONES EXCEPT CB, LI & HI THEN 5	25 ADJ ST & ALL ZONES EXCEPT CB, LI & HI THEN 5	15 (ALL)	25 ADJ ST & ALL ZONES EXCEPT CB, LI & HI THEN 5
HI - HEAVY INDUSTRIAL	N/A	N/A	N/A	50 EXCEPT ADJ HI THEN 10	50 EXCEPT ADJ HI THEN 10	50 EXCEPT ADJ HI THEN 10	N/A	50 EXCEPT ADJ HI THEN 10
P - PUBLIC	N/A	N/A	N/A	25	25	25	15	25
MU - MIXED USE	25	5 (25 ST)	20	25	5 (25 ST)	20	N/A	N/A

* SIDE SETBACKS MAY BE REDUCED TO 0' (ZERO FEET) WHEN CONSTRUCTION METHODS ARE USED TO SEPARATE STRUCTURES SUCH AS DUPLEX AND TOWNHOUSE DEVELOPMENTS

CHAPTER 2 ZONE DISTRICTS

4-2-100 DISTRICT AR - AGRICULTURAL RESIDENTIAL

Areas primarily used for large lot detached residential development at a density which typifies a rural lifestyle, and which may include some agricultural uses, are considered agricultural residential.

Uses by Right

- i. Accessory structures
- ii. Family child care home
- iii. Home occupations
- iv. Single-family residential
- v. Family child care centers
- vi. Bed and breakfasts
- vii. Churches, temples or other places of worship

- viii. Primary and secondary schools
- ix. Accessory living quarters
- x. Small Wind Energy Systems (Small Wind Energy Systems setbacks shall be equal to the largest district setbacks or the total height of the system, whichever is greater.)

b. Uses Requiring Board Approval

The following uses may be permitted by the Board:

- i. Animal hospitals or clinics
- ii. Commercial stables, arenas, kennels, bird farms and show barns
- iii. Child care centers - minor and major
- iv. Commercial nurseries or landscaping businesses
- v. Other uses similar to those permitted in this district

c. Density

Minimum area for any use in this district is 5 acres for small wastewater system permits, computed consistent with the following exceptions:

- i. If the property is served by an approved central water distribution system, and/or sewer collection and treatment system, the minimum residential use lot or residential use tract area in this district may be reduced subject to a review and approval from the Wyoming Department of Environmental Quality. The computation of lot or tract sizes in this exception shall not include adjacent public or private rights-of-way, easements or reservations for roadway purposes.
- ii. Lots or tracts platted and recorded with the County Clerk prior to May 5, 1987 shall be a minimum of 2.5 acres for any use in this district.
- iii. Lots or tracts platted and recorded with the County Clerk prior to June 5, 1979 may be used as building sites for uses allowed in this district if adequate provisions can be made for water and sewer/septic.
- iv. Minimum area for water well systems – refer to Section 2-1-103 c. i. for subdivisions approved after the adoption of these regulations.
- v. Minimum acreage may be averaged with environmental health

approval but shall not have an average below 5.25 acres per tract unless meeting (c)(i) above.

d. Setbacks

Accessory structure setbacks shall conform to Section 2-2-118 of this regulation. All other setbacks – refer to table in Section 4-1-104.

e. Commercial Use Site Plan Requirements

A County-approved site and landscape plan shall be required in accordance with Sections 2-2-133 and 2-2-134 of these regulations. Commercial operations may cover 85% of the tract

4-2-101 DISTRICT A1 - AGRICULTURAL AND RURAL RESIDENTIAL

Areas in a natural state or in which the growing of crops, flowers, trees, or pasture, or the production of livestock or other farming or ranching activity is practiced, are considered agricultural and rural residential.

a. Uses by Right

- i. Agriculture and uses incidental to an agricultural operation
- ii. Family child care home
- iii. Family child care centers
- iv. Home occupations
- v. Single-family residential
- vi. Small Wind Energy Systems (Small Wind Energy Systems setbacks shall be equal to the largest district setbacks or the total height of the system, whichever is greater.)
- vii. Animal hospitals or clinics
- viii. Bed and breakfasts
- ix. Cemeteries
- x. Churches, temples or other places of worship
- xi. Duplexes
- xii. Primary and secondary Schools
- ~~xiii. Commercial nurseries and landscaping businesses~~
- xiv. Road side farm stands
- xv. Accessory living quarters

b. Uses Requiring Board Approval

The following uses may be permitted by the Board:

- i. Commercial sales of agricultural related products, not including fuel or petroleum products
- ii. Work camps
- iii. Any other similar use
- iv. Commercial stables, arenas, kennels, bird farms and show barns
- v. Commercial nurseries and landscaping businesses

c. Density

- i. The minimum lot size for any use in this district is ten (10) acres. For single family uses, the density may be averaged within the subdivision/ development, provided that no lot or tract shall be less than six (6) acres gross.
- ii. The following exceptions are permissible:
- iii. Lots or tracts platted and recorded with the County Clerk prior to November 2, 1999, shall be a minimum of 5 acres.
- iv. Lots or tracts platted and recorded with the County Clerk prior to May 5, 1987, may be a minimum of 2.5 acres.
- v. Lots or tracts platted and recorded with the County Clerk prior to June 5, 1979, may be used as building sites if adequate provisions can be made for water and sewer/septic.

d. Setbacks

Accessory structure setbacks shall conform to Section 2-2-118 of this regulation. All other setbacks – refer to table in Section 4-1-104.

e. Commercial Use Site Plan Requirements

A County-approved site and landscape plan shall be required in accordance with Sections 2-2-133 and 2-2-134 of these regulations. Commercial operations may cover 85% of the tract

DISTRICT A2 - AGRICULTURAL

Areas in a natural state or in which the growing of crops, flowers, trees, or pasture, or the production of livestock, or other farming or ranching activity is practiced, are

considered agricultural.

- f. Uses by Right
 - i. Agriculture and uses incidental to an agricultural operation
 - ii. Animal hospitals or clinics
 - iii. Bed and breakfasts
 - iv. Cemeteries
 - ~~v. Commercial nurseries or landscaping businesses~~
 - vi. Family child care home
 - vii. Family child care centers
 - viii. Home occupations
 - ix. Single-family residential
 - x. Small Wind Energy Systems (Small Wind Energy Systems setbacks shall be equal to the largest district setbacks or the total height of the system, whichever is greater.)
 - xi. Churches, temples or other places of worship
 - xii. Duplexes
 - xiii. Child care centers - minor
 - xiv. Primary and secondary schools.
 - xv. Commercial stables, arenas, kennels, bird farms and show barns
 - xvi. Farm stands
 - xvii. Accessory living quarters
- g. Uses Requiring Board Approval

The following uses may be permitted by the Board:

- i. Agricultural equipment or product sales
- ii. Commercial animal processing plants
- iii. Commercial feed lots
- iv. Golf courses
- v. Race tracks

- vi. Work camps
- vii. Any other similar use
- viii. Commercial nurseries and landscaping businesses

h. Density

The minimum lot size for any use in this district is twenty (20) acres.

i. Setbacks

Accessory structure setbacks shall conform to Section 2-2-118 of this regulation. All other setbacks – refer to table in Section 4-1-104.

j. Commercial Use Site Plan Requirements

A County-approved site and landscape plan shall be required in accordance with Sections 2-2-133 and 2-2-134 of these regulations. Commercial operations may cover 85% of the tract

4-2-114 District LU- Land Use

To promote the health, safety and the general welfare of the citizens of Laramie County. The intent is to create a safe living and working environment, and to improve the economic vitality of the county.

a. Uses by right

Any use not listed as a use requiring board approval below

b. Uses requiring board approval

- i. Concentrated animal feeding operation
- ii. Shooting sports range
- iii. Large scale wind and solar and;
- iv. Adult entertainment businesses

c. Density – minimum lot size

i. Area covered by AMEC memo January 31, 2014:

Within zones 2 and 4, lot size is to be 5.25 acres gross, whichever is larger. Or The minimum lot size may be averaged over the ownership parcel in zones 1 and 3 or;

- ii. For area not included in the AMEC memo the lot size shall meet the requirements established by the Cheyenne/Laramie County division of environmental health pertaining to wastewater treatment or;

iii. Developments approved by DEQ for sewage treatment and the State Engineers Office's water department.

d. Setbacks

See residential and accessory setback tables

e. Commercial use site plan requirements

A county-approved site and landscape plan shall be required in accordance with sections 2-2-133 and 2-2-134 of these regulations. Commercial operations may cover 85% of the tract

RESOLUTION # _____

RESOLUTION GIVING PUBLIC NOTICE OF LARAMIE COUNTY'S INTENT TO AMEND THE AMENDED 2019 LARAMIE COUNTY LAND USE REGULATIONS

WHEREAS, Wyoming State Statutes § 16-3-103; §18-5-201 to 18-5-208; §18-5-301 to 18-5-315 authorize Laramie County, in promoting the public health, safety, morals and general welfare of the county, to regulate the use of land through zoning in unincorporated Laramie County; and

WHEREAS, WYO. STAT. ANN. § 16-3-103, requires 45 days public notice and a reasonable opportunity for public comment before Laramie County may adopt, amend, or repeal rules and regulations;

WHEREAS, the proposed amendments to the Laramie County Land Use Regulations are attached hereto as "Exhibit A" and incorporated into this resolution by this reference.

NOW THEREFORE BE IT RESOLVED BY THE GOVERNING BODY OF LARAMIE COUNTY, WYOMING, that notice is hereby given to the public that Laramie County intends to amend the amended 2019 Laramie County Land Use Regulations; that copies of the proposed Regulations may be reviewed at the Laramie County Clerk's Office, 309 West 20th Street, Room 1513, Cheyenne, Wyoming and/or the Planning and Development Office, 3966 Archer Parkway, Cheyenne, Wyoming or on the Laramie County Planning and Development website at <https://www.laramiecountywy.gov/departments/PlanningDevelopment/index.aspx> ; that all interested persons may submit written comments to the Laramie County Clerk, 309 West 20th Street, P.O. Box 608, Cheyenne, Wyoming 82003 or via email at planning@laramiecountywy.gov, no later than 12:00 p.m. on September 16th, 2022; that there shall be a regularly scheduled Laramie County Planning Commission meeting on September 22nd, 2022 at 3:30 p.m. and a regularly scheduled Laramie County Commissioner's meeting on October 4th, 2022 at 3:30 p.m. Both meetings will be held in the Laramie County Commissioners Boardroom on the 3rd floor of the Historic County Courthouse, 310 West 19th Street, Cheyenne, Wyoming; and, that this notice shall be published once in the Wyoming Tribune-Eagle as soon as practicably possible.

PRESENTED, READ AND ADOPTED this 2nd day of August 2022

LARAMIE COUNTY BOARD OF COMMISSIONERS

Troy Thompson, Chairman

ATTEST:

Debra K. Lee, Laramie County Clerk

Reviewed and approved as to form:



Mark T. Voss, Laramie County Attorney