

**AGREEMENT TO PROVIDE THE PURCHASE OF A NEW COMMERCIAL ASPHALT
PAVER
between
LARAMIE COUNTY, WYOMING and WYOMING MACHINERY COMPANY).**

This Agreement is made and entered into by and between Laramie County, Wyoming, 310 W. 19th Street, Suite 300, Cheyenne, Wyoming, 82001 (“COUNTY”) and Wyoming Machinery Company located at 5300 Old Yellowstone Hwy., Casper, WY 82604 (“CONTRACTOR”).

I. PURPOSE

The CONTRACTOR is to provide the purchase of a new Weiler P385C Commercial Asphalt Paver, as requested in the RFB issued by the Laramie County Public Works Department.

II. TERM

This Agreement shall commence on the date last executed by the duly authorized representatives of the parties to this Agreement, and shall remain in force until the project is completed by CONTRACTOR and accepted by COUNTY as set forth in the Agreement.

III. PAYMENT

COUNTY shall pay CONTRACTOR for services upon receipt of the CONTRACTOR’S invoice to the COUNTY as detailed in the RFB attached hereto as Exhibit A, which is fully incorporated herein. The total payment to CONTRACTOR under this Agreement shall not exceed \$266,660.00 (bid amount), unless negotiated by both parties in writing. Payment will be made to CONTRACTOR for materials upon invoice. No payment shall be made before the last signature is affixed to this Agreement. Payments shall be in accordance with Wyo. Stat. § 16-6-602 (as amended). This project is being paid for with Federal ARPA Funds (ALN #21.027).

IV. RESPONSIBILITIES OF CONTRACTOR

- A. CONTRACTOR shall provide a new Weiler P385C Commercial Asphalt Paver as specified in the bid attached hereto as Exhibit B.
- B. CONTRACTOR shall work closely with COUNTY in coordinating the purchase and delivery, CONTRACTOR will work with COUNTY as needed in accordance with such individuals or curriers as deemed appropriate by COUNTY.
- C. CONTRACTOR agrees to retain all required records for three (3) years after the County makes final payment and all other matters relating to the Agreement are concluded. CONTRACTOR agrees to permit access by the COUNTY or any of its duly authorized representatives to any books, documents, papers and records of the CONTRACTOR, which are directly pertinent to this specific Agreement for

purposes including but not limited to audit, examination, excerpts, and transcriptions.

V. GENERAL PROVISIONS

A. Termination: This Agreement may be terminated (a) by either party at any time for failure of the other party to comply with the terms and conditions of this agreement; (b) by either party, with thirty (30) days' prior written notice to the other party; or (c) upon mutual written agreement by both parties.

B. Entire Agreement: This Agreement (5 pages), and the attached RFB (13 pages) and the attached Proposal (31 pages) represent the entire and integrated agreement and understanding between the parties and supersede all prior negotiations, statements, representations and agreements, whether written or oral.

C. Assignment: Neither this Agreement, nor any rights or obligations hereunder shall be assigned or delegated by a party without the prior written consent of the other party.

D. Modification: This Agreement shall be modified only by a written agreement, duly executed by all parties hereto.

E. Invalidity: If any provision of this Agreement is held invalid or unenforceable by any court of competent jurisdiction, or if the COUNTY is advised of any such actual or potential invalidity or unenforceability, such holding or advice shall not invalidate or render unenforceable any other provision hereof. It is the express intent of the parties that the provisions of this Agreement are fully severable.

F. Applicable Law and Venue: The parties mutually understand and agree this Agreement shall be governed by and interpreted pursuant to the laws of the State of Wyoming. If any dispute arises between the parties from or concerning this Agreement or the subject matter hereof, any suit or proceeding at law or in equity shall be brought in the District Court of the State of Wyoming, First Judicial District, sitting at Cheyenne, Wyoming. The foregoing provisions of this paragraph are agreed by the parties to be a material inducement to CONTRACTOR and to COUNTY in executing this Agreement. This provision is not intended nor shall it be construed to waive COUNTY's governmental immunity as provided in this Agreement.

G. Contingencies: CONTRACTOR certifies and warrants no gratuities, kickbacks or contingency fees were paid in connection with this Agreement, nor were any fees, commissions, gifts or other considerations made contingent upon the award of this Agreement.

H. Discrimination: All parties agree they will not discriminate against any person who performs work under the terms and conditions of this Agreement because of race, color, gender, creed, handicapping condition, or national origin.

I. **ADA Compliance:** All parties agree they will not discriminate against a qualified individual with disability, pursuant to law as set forth in the Americans With Disabilities Act, P.L. 101-336, 42 U.S.C. § 12101, *et seq.*, and/or any properly promulgated rules and regulations relating thereto.

J. **Governmental/Sovereign Immunity:** COUNTY does not waive its Governmental/Sovereign Immunity, as provided by any applicable law including W.S. § 1-39-101 *et seq.*, by entering into this Agreement. Further, COUNTY fully retains all immunities and defenses provided by law with regard to any action, whether in tort, contract or any other theory of law, based on this Agreement.

K. **Indemnification:** To the fullest extent permitted by law, CONTRACTOR agrees to indemnify and hold harmless COUNTY, its elected and appointed officials, employees and volunteers from any and all liability for injuries, damages, claims, penalties, actions, demands or expenses arising from or in connection with work performed by or on behalf of CONTRACTOR for COUNTY except to the extent liability is caused by the sole negligence or willful misconduct of COUNTY or its employees. CONTRACTOR shall carry liability insurance sufficient to cover its obligations under this provision and provide COUNTY with proof of such insurance.

L. **Third Parties:** The parties do not intend to create in any other individual or entity the status of third party beneficiary, and this Agreement shall not be construed so as to create such status. The rights, duties and obligations contained in this Agreement shall operate only between the parties to the Agreement, and shall inure solely to the benefit of the parties to this Agreement.

M. **Conflict of Interest:** COUNTY and CONTRACTOR affirm, to their knowledge, no CONTRACTOR employee has any personal beneficial interest whatsoever in the agreement described herein. No staff member of CONTRACTOR, compensated either partially or wholly with funds from this Agreement, shall engage in any conduct or activity, which would constitute a conflict of interest relative to this Agreement.

N. **Force Majeure:** Neither party shall be liable to perform under this Agreement if such failure arises out of causes beyond control, and without the fault or the negligence of said party. Such causes may include, but are not restricted to, Act of God or the public enemy, fires, floods, epidemics, quarantine restrictions, freight embargoes, and unusually severe weather. In every case, however, a failure to perform must be beyond the control and without the fault or the negligence of said party.

O. **Limitation on Payment:** COUNTY's payment obligation is conditioned upon the availability of funds, which are appropriated or allocated for the payment of this obligation. If funds are not allocated and available for the continuance of the services and equipment provided by CONTRACTOR the Agreement may be terminated by COUNTY at the end of the period for which funds are available. COUNTY shall notify CONTRACTOR at the earliest possible time of the services, which will or may be affected by a shortage of funds. At the earliest possible time means at least thirty (30) days before the shortage will affect payment of claims, if COUNTY knows of the shortage at least thirty (30) days in advance. No penalty shall accrue to

COUNTY in the event this provision is exercised, and COUNTY shall not be obligated or liable for any future payments due or for any damages as a result of termination under this provision. This provision shall not be interpreted or construed to permit COUNTY to terminate this Agreement in order to acquire similar services from another party.

P. Notices: All notices required and permitted under this Agreement shall be deemed to have been given, if and when deposited in the U.S. Mail, properly stamped and addressed to the party for whom intended at such parties' address listed herein, or when personally delivered personally to such party. A party may change its address for notice hereunder by giving written notice to the other party.

Q. Compliance with Law: CONTRACTOR shall comply with all applicable laws, regulations and ordinances, whether Federal, State or Local.

[The remainder of this page is intentionally left blank]

**AGREEMENT TO PROVIDE THE PURCHASE OF A NEW COMMERCIAL ASPHALT
PAVER
between
LARAMIE COUNTY, WYOMING and WYOMING MACHINERY COMPANY).**

LARAMIE COUNTY, WYOMING

By: _____ Date _____
Chairman Laramie County Commissioners

ATTEST:

By: _____ Date _____
Debra Lee, Laramie County Clerk

CONTRACTOR: WYOMING MACHINERY COMPANY

By: _____ Date 06/09/2023
Name: 
Title:

This Agreement is effective the date of the last signature affixed to this page.

REVIEWED AND APPROVED AS TO FORM ONLY:

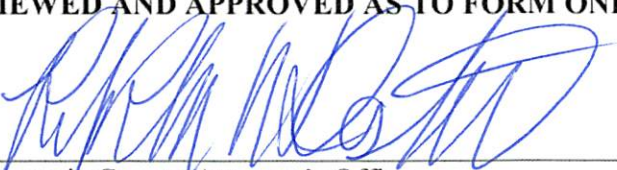
By:  Date 6/23/23
Laramie County Attorney's Office

Bid Tabulation- Public Works-Asphalt Paver
Thursday June 1, 2023 at 2:15pm

<u>Bidder</u>	<u>Sam.gov Registration</u>	<u>Experience</u>	<u>Meets Specifications</u>	<u>Schedule</u>	<u>Past Performance</u>	<u>Bid Price</u>
Cate Equipment-Option 1	Yes-good through 3/1/24	Yes	Leeboy 8608-8 inches short on width	Estimated Delivery Dec 2023-Jan 2024	County has not worked with vendor	\$296,190 + Freight
Cate Equipment-Option 2	Yes-good through 3/1/24	Yes	Leeboy 8616-2 inches short on width	Estimated Delivery Dec 2023-Jan 2024	County has not worked with vendor	\$324,950 + Freight
Cate Equipment-Option 3	Yes-good through 3/1/24	Yes	Leeboy 8530-2 inches short on width	Estimated Delivery Dec 2023-Jan 2024	County has not worked with vendor	\$317,625 + Freight
Honnen Equipment Company of Wyoming Option 1	Yes-good through 3/29/24	Yes	Vogele New 1700-3i	2 weeks + training	Yes	\$ 496,519.49
Honnen Equipment Company of Wyoming Option 2	Yes-good through 3/29/24	Yes	No-VF-500 Screed <u>used</u> 229 hours	In Stock	Yes	\$ 395,000.00
Wyoming Machinery	Yes-good through 12/28/23	Yes	Weiler P385C	April 2024 or sooner	Yes	\$ 266,660.00

REQUEST FOR BIDS
Laramie County Public Works
One (1) new Commercial Asphalt Paver
Closing Date: June 1, 2023

Purpose of Request for Bids (RFB)

Laramie County is soliciting competitive bids for qualified vendors who can provide one (1) new Commercial Asphalt Paver for Laramie County Public Works. This project is being funded with Federal ARPA funds (ALN # 21.027) and selected vendor will be required to be registered in sam.gov.

Table of Contents

1.0 PURPOSE & OVERVIEW2

2.0 SCOPE OF SERVICES2

3.0 GENERAL TERMS & CONDITIONS5

 3.1 RFB CLOSING DATE5

 3.2 DELIVERY OF BIDS5

 3.3 PRE-BID INFORMATION5

 3.4 PUBLIC RFB OPENING.....5

 3.5 BID FORM.....5

 3.6 QUESTIONS CONCERNING RFB6

 3.7 CLARIFICATION AND ADDENDA.....6

 3.8 AWARD6

 3.9 CONTRACT7

 3.10 DISCLOSURE OF RFB CONTENT7

 3.11 RESPONDENT’S RESPONSIBILITY.....7

 3.12 PAYMENT TERMS7

 3.13 MINOR IRREGULARITIES.....8

 3.14 DEVIATIONS8

 3.15 SELECTION CRITERIA8

 3.16 TERMINATION / CANCELLATION OF CONTRACT.....8

 3.17 INCURRED EXPENSES.....9

 3.18 PRESENTATIONS BY RESPONDENTS.....9

 3.19 MINIMUM SPECIFICATIONS9

 3.20 RESPONDENT’S PERSONNEL9

 3.21 BID ACCEPTANCE/REJECTION10

4.0 4.0 SUBMITTAL REQUIREMENTS.....10

5.0 5.0 DISCLOSURES10

6.0 BID FORM.....13

1.0 Purpose & Overview

Laramie County Public Works is soliciting competitive, sealed bids from qualified vendors to provide one (1) new Commercial Asphalt Paver.

2.0 Scope of Services

Specifications for Bid

Estimated date of delivery: _____

General

- Diesel engine (120 Horse Power min)
 - Meets specifications: Yes No
- Adjustable screed (8' – 15'8" preferred)
 - Meets specifications: Yes No
- Hopper capacity (8 tons min)
 - Meets specifications: Yes No
- Heated screed
 - Meets specifications: Yes No
- Vibratory screed (500 Vibrations Per Minute min)
 - Meets specifications: Yes No
- Generator (12kw min)
 - Meets specifications: Yes No
- 12" augers with reverse function
 - Meets specifications: Yes No
- 19" truck clearance
 - Meets specifications: Yes No
- Spray down tank (5-gallon capacity min)
 - Meets specifications: Yes No
- Truck dump width 118" (inside)
 - Meets specifications: Yes No
- Lockable vandal covers
 - Meets specifications: Yes No

- Adjustable hopper sides
 - Meets specifications: Yes No
- Conveyor with reverse function (Heavy Duty chains and flights)
 - Meets specifications: Yes No
- Hydrostatic drive
 - Meets specifications: Yes No
- Automatic track tensioning
 - Meets specifications: Yes No
- 3/8" thick screed plates (main and extension)
 - Meets specifications: Yes No
- Sonic feed sensors
 - Meets specifications: Yes No
- Manual crown control (+3%)
 - Meets specifications: Yes No
- Rear walkways
 - Meets specifications: Yes No
- Truck push rollers (hydraulically extended)
 - Meets specifications: Yes No
- LED strobe and work lighting
 - Meets specifications: Yes No
- Grade and slope controls
 - Meets specifications: Yes No
- Remote grease lines
 - Meets specifications: Yes No
- Screed mounted control panels
 - Meets specifications: Yes No

Safety & Other

- Paper copies of Service, Repair, and Parts Manuals (to be supplied upon delivery)
 - Meets specifications: Yes No
- One complete set of filters shall be provided
 - Meets specifications: Yes No

Warranty and Training

TRAINING AND DIAGNOSTICS:

With delivery of Commercial Asphalt Paver, a qualified representative shall instruct County Operators and Mechanics in the proper operation, servicing, lubrication, adjustments, and preventative maintenance of the machine(s).

A complete set of printed service, parts, operator, and repair manuals and diagnostic software shall be supplied with the Commercial Asphalt Paver (if applicable).

WARRANTY PROGRAM AND SERVICE

Vendor will provide, in letter form only, the type of warranty supplied on quoted Commercial Asphalt Paver. The letter shall include the type of service provided, guarantee of parts, and cost of service during warranty period. The vendor may also provide any other material which they feel gives their machine an advantage on service and warranty. Please state any extended warranties and their associated cost in the warranty period.

The ability of the bidder to provide superior warranty and service may be used to determine a successful bidder.

Printed specifications on machine bid shall be presented. All above specifications filled in must be legible. With delivery of machine(s) and components, Manufacturer's Statement of Origin shall be supplied.

Additional Notes:

- A. The respondent shall provide the following information for each proposed system:
 1. A complete bid including all related costs for providing the equipment, supplies and installation as outlined above.
 2. Delivery of all equipment, supplies, and installation.
 3. Enter into a written contract for work with Laramie County.
 4. Contractor shall comply with all applicable Federal and State statutes and regulations as well as local ordinances.
- B. The person or persons provided by the respondent to complete work shall be fully qualified to provide said services.
- C. All work provided by the respondent shall be in conformance with local, state, and Federal rules and regulations.
- D. All equipment shall be responsive to the needs of the County, shall be performed in accordance with County programs, policies, and procedures, and shall utilize appropriate methods and techniques.

- E. All records, including digital information, video tapes and audio tapes, related to the contract services performed for the County shall be subject to the Wyoming Public Records Laws and shall be maintained and made available in accordance with those laws and public records policies and procedures of the County. Records shall be made available to the County without question upon request of the County, in accordance with the requirements of law. Citizen requests for such records shall be processed through the County. All records, including all types of electronic records, related to the contract and services performed there under shall be the property of the County at the end of the contract, or at the end of the County's fiscal year, or upon demand of the County, whichever occurs first. The County shall specify the minimum records to be maintained by the respondent. The respondent may maintain additional records at its discretion.

3.0 General Terms & Conditions

3.1 RFB Closing Date

Bids must be received by the Laramie County Public Works Department (LCPW) at 13797 Prairie Center Circle, Cheyenne, Wyoming 82009 no later than **2:00 PM, MST, on June 1, 2023**. Bids received after this time will not be considered. Please note for bid delivery purposes, the hours of operation for LCPW are Monday through Thursday, 6:00 AM to 4:30 PM, MST.

3.2 Delivery of Bids

All bids shall be sealed and delivered or mailed to the address of Laramie County Public Works (faxes and emails will not be accepted).

3.3 Pre-bid Information

No specific pre-bid meeting will be held. Each respondent shall contact John Poelma 307-633-4690 or john.poelma@laramiecountywy.gov to discuss the bid with the County, if needed.

3.4 Public RFB Opening

Only the names of the vendors submitting bids will be read aloud at the RFB opening. The bids will be available for inspection during normal business hours in the Laramie County Public Works Department within three (3) working days of the closing date, by appointment. Bid opening will occur on June 1, 2023, at 2:15 PM at the Laramie County Public Works office. A complete tabulation of bids will be available after it is completed.

Individuals covered by the Americans with Disabilities Act of 1990 in need of accommodations to attend public RFB openings or meetings should contact the Public Works Department in Cheyenne at (307) 633-4690 at least five (5) days prior to the date.

3.5 Bid Form

- A. See Submittal Requirements for complete details.

- B. Each respondent shall submit THREE (3) complete sets of the bid form, one marked "ORIGINAL" and TWO (2) marked "COPY". The bid shall be submitted on an exact copy of the attached bid form.
- C. The bid form must be signed by an official authorized to legally bind the respondent to all RFB provisions contained herein.
- D. Terms and conditions differing from those in this RFB may be cause for disqualification of the bid.

3.6 Questions Concerning RFB

Questions concerning any portion of this RFB should be directed in writing to John Poelma, Public Works Department, named below, who shall be the official point of contact for this RFB. Mark cover page or envelope(s) "**Commercial Asphalt Paver.**"

Submit questions to:

John Poelma
Assistant Director
Public Works
(307) 633-4690

john.poelma@laramiecountywy.gov

3.7 Clarification and Addenda

It is incumbent upon each respondent to carefully examine all specifications, terms, and conditions contained herein. Any inquiries, suggestions, or requests concerning interpretation, clarification or additional information shall be made in writing, (facsimile transmissions acceptable) through the Assistant Director named above. The County will not be responsible for any oral representation(s) given by any employee, representative or others. The issuance of a written addendum is the only official method by which interpretation, clarification or additional information can be given.

If it becomes necessary to revise or amend any part of this RFB, notice may be obtained by accessing the Laramie County web site. Respondents in their bid must acknowledge receipts of amendments. **Each respondent should ensure that they have received all addenda and amendments to this RFB before submitting their bid. Please check the Laramie County web site at <http://www.laramiecountywy.gov> for any addenda.**

3.8 Award

The County reserves the right to award the contract to the respondent(s) that the County deems to offer the best overall bid(s). The County is therefore not bound to accept a bid on the basis of lowest price. In addition, the County at its sole discretion, reserves the right to cancel this RFB, to modify the quantities of product we purchase, to reject any and all bids, to waive any and all informalities and/or irregularities, or to re-advertise with either the identical or revised specifications, if it is deemed to be in the best interest of the County to do so. The County also

reserves the right to make multiple awards, based on experience and qualifications if it is deemed to be in the County's best interest.

3.9 Contract

The contents of this RFB and all provisions of the successful bid deemed pertinent by the County may be incorporated into a contract and become legally binding. A separate contract document will be issued.

The County Commissioners are the sole Contracting Officer for Laramie County, Wyoming, and only he/she or his/her designee is authorized to make changes to any contract. The County shall be responsible for only those orders placed by the County on an authorized signed Purchase Order or Price Agreement. The County shall not be responsible for any order, change, substitution or any other discrepancy from the Purchase Order or Price Agreement. If there is any question about the authenticity of a Purchase Order, Price Agreement or change order, the respondent should promptly contact the Public Works Department at (307) 633-4690.

3.10 Disclosure of RFB Content

All material submitted becomes the property of the County and may be returned only at the County's option. The County has the right to use any or all ideas presented in any reply to this RFB. Selection or rejection of any bid does not affect this right.

3.11 Respondent's Responsibility

A respondent, by submitting a bid represents that:

- A. The respondent has read and understands the RFB in its entirety that and the bid is made in accordance therewith, and
- B. The respondent possesses the capabilities, resources, and personnel necessary to provide efficient and successful service to the County, and;
- C. Before submitting a bid, each respondent shall make all investigations and examinations necessary to ascertain site and/or local conditions and requirements affecting the full performance of the contract and to verify any representations made by Laramie County upon which the respondent will rely. If the respondent receives an award because of its bid submission, failure to have made such investigations and examinations will in no way relieve the respondent from its obligations to comply in every detail with all provisions and requirements of the contract, nor will a plea of ignorance of such conditions and requirements be accepted as a basis for any claim by the respondent for additional compensation or relief.

3.12 Payment Terms

The County will remit full payment on all undisputed invoices within forty-five (45) days from receipt by the appropriate person(s) (to be designated at time of contract) of the invoice(s) or receipt of all products or services ordered.

3.13 Minor Irregularities

The County reserves the right to waive minor irregularities in bids, providing such action is in the best interest of the County. Minor irregularities are defined as those that have no adverse effect on the County's best interests and will not affect the outcome of the selection process by giving the respondent an advantage or benefit not enjoyed by other respondents.

3.14 Deviations

All bids must clearly and with specific detail, note all deviations to the exact requirements imposed upon the respondent by the General Terms & Conditions. Such deviations must be stated upon the Bid Form; otherwise, Laramie County will consider the subject bids as being made in strict compliance with said General Terms & Conditions to respondents; the respondent being held therefore accountable and responsible. Respondents are hereby advised that Laramie County will only consider bids that meet the exact requirements imposed by the General Terms & Conditions; except, however, said bids may not be subject to such rejection where, at the sole discretion of Laramie County, the stated deviation is considered to be equal or better than the imposed requirement and where said deviation does not destroy the competitive character of the RFB process by affecting the amount of the bid such that an advantage or benefit is gained to the detriment of the other respondents.

3.15 Selection Criteria

Each bid shall be evaluated using the following criteria:

1. Proper submittal of ALL documentation as required by this bid
2. Overall scope and quality of the proposed project
3. Meeting or exceeding the requirements of the RFB
4. Quality and compatibility of the work proposed
5. Ability to accomplish project in a timely manner
6. The benefits to Laramie County as it pertains to:
 - a. Related experience in the areas covered in the RFB
 - b. Past record of performance on contracts with government agencies and private industry with respect to such factors as control of costs, quality of work and ability to meet schedules
 - c. Experience, ability, and overall quality of past and current projects

3.16 Termination / Cancellation of Contract

The County reserves the right to cancel the contract without cause with a minimum thirty (30) days written notice. Termination or cancellation of the contract will not relieve the respondent of any obligations for any deliverables entered into prior to the termination of the contract (i.e., reports, materials, statements of accounts, etc., required and not received). Termination or

cancellation of the contract will not relieve the respondent of any obligations or liabilities resulting from any acts committed by the respondent prior to the termination of the contract.

3.17 Incurred Expenses

This RFB does not commit Laramie County to award a contract. Nor shall Laramie County be responsible for any cost or expense which may be incurred by the respondent in preparing and submitting the bid called for in this RFB, or any cost or expense incurred by the respondent prior to the execution of a contract agreement.

3.18 Presentations by Respondents

Laramie County, at its sole discretion, may ask individual respondents to make oral presentations and/or demonstrations without charge to the County.

The County reserves the right to require any respondent to demonstrate to the satisfaction of the County that the respondent has the fiscal and managerial abilities to properly furnish the services proposed and required to fulfill the contract. The demonstration must satisfy the County and the County shall be the sole judge of compliance.

Respondents are cautioned not to assume that presentations will be required and should include all pertinent and required information in their original bid package.

3.19 Minimum Specifications

The specifications listed in the Scope of Service are the minimum required performance specifications for this RFB. They are not intended to limit competition nor specify any particular respondent, but to ensure that the County receives quality services.

3.20 Respondent's Personnel

The respondent shall be responsible for ensuring that its employees, agents and subcontractors comply with all applicable laws and regulations and meet all federal, state and local requirements related to their employment and position. The respondent certifies that it does not and will not during the performance of the contract employ illegal alien workers or otherwise violate the provisions of the federal Immigration Reform and Control Act of 1986, as amended. During the performance of the contract, the respondent agrees to the following:

The respondent shall not discriminate against any employee or applicant for employment because of race, religion, color, sex, age, handicap or national origin, except when such condition is a bona fide occupational qualification reasonably necessary for the normal operations of the respondent.

The respondent agrees to post in conspicuous places, visible to employees and applicants for employment, notices setting forth the provisions of this nondiscrimination clause.

The respondent, in all solicitations or advertisements for employees placed by or on behalf of the respondent, shall state that such respondent is an Equal Opportunity Employer.

3.21 Bid Acceptance/Rejection

The County reserves the right to accept or reject any or all bids received as a result of this RFB, or to negotiate separately with competing respondents, and to waive any informalities, defects, or irregularities in any bid, or to accept that bid or bids, which in the judgment of the proper officials, is in the best interest of the County.

4.0 Submittal Requirements

Bids shall include all the information solicited in this RFB, and any additional data that the respondent deems pertinent to the understanding and evaluating of the bid. Bids shall be organized, and sections tabbed in the following order. The respondent should not withhold any information from the written response in anticipation of presenting the information orally or in a demonstration, since oral presentations or demonstrations may not be solicited. All bids shall include at minimum:

Tab 1 – Respondent’s Profile

A brief profile of the firm, including the firm’s overall qualifications to provide services necessary to fulfill all requirements outlined in the project Scope of Work.

Tab 2 - Completed Bid Form (use attached form)

Tab 3 – References

List at least three (3) recent references where the equivalent project(s) have been conducted within the past five years.

Tab 4 – Other Information

Include any additional information you believe will assist the County in the selection process of qualified respondents. Please be succinct.

5.0 Disclosures

The laws of Wyoming require that the contents of all bids shall be placed in the public domain and be open to inspection by interested parties. Trade secrets or proprietary information that are recognized as such and are protected by law may be withheld if clearly identified as such in the bid. The entire bid cannot be designated as proprietary or a trade secret. If a request is received to examine portions designated as proprietary or a trade secret, Laramie County will notify the vendor to permit the vendor to defend the proprietary nature of the information.

If a respondent discovers any ambiguity, conflict, discrepancy, exclusionary specifications, omission, or other error in this document, the respondent shall immediately notify the issuing office. If the respondent is awarded a contract, then such respondent will not be entitled to additional compensation, relief, or time by reason of the error or its later correction.

The successful respondent will be expected to enter into a contract with Laramie County upon terms acceptable to the County. Respondent will be required to be registered in Sam.gov to receive federal ARPA funding as a contractor/vendor to this RFB.

Following the award of the contract, responses to this bid are subject to release as public information unless specific parts of the response can be shown to be exempt from the laws of the State of Wyoming. Respondents are advised to consult with their legal counsel regarding disclosure issues and take the appropriate precautions to safeguard trade secrets or any other proprietary information. Laramie County assumes no obligation or responsibility for asserting legal arguments on behalf of potential respondents.

If a respondent believes that parts of a bid are confidential then the respondent must so specify. The respondent must mark in bold red letters the term **“CONFIDENTIAL”** on that part of the response, which the respondent believes to be confidential. The respondent must submit in writing specific detailed reasons, including any relevant legal authority, stating why the respondent believes the material to be confidential. Vague and general claims as to confidentiality will not be accepted. Laramie County will be the sole judge as to whether a claim is general and/or vague in nature. All parts of bids, which are not marked as confidential, will be automatically considered public information after the contract is awarded. The successful bid may be considered public information even though parts are marked confidential.

Bids must be signed by a person authorized to commit the respondent to provide the services requested in this RFB. Submission of a signed bid will be interpreted to mean the respondent has agreed to all terms and conditions set forth in all of the sheets which make up this RFB.

Laramie County accepts no obligations for the costs incurred in responding to this RFB in anticipation of being awarded a contract. Laramie County reserves the right to reject any and all submitted bids. It is understood that all bids become the property of Laramie County and will be available for public inspection. No obligation is made by retention of these bids, nor is Laramie County committed to awarding a contract as a result of this RFB.

Each respondent must disclose any existing or potential conflict of interest relative to the performance of the requirements of this bid. Examples of potential conflicts may include an existing business or personal relationship between the respondent, its principal or any affiliate or subcontractor, with Laramie County or any other entity or person involved in any way in the project that is the subject of this RFB. Similarly, any personal or business relationship between the respondent, the principals, or an affiliate or subcontractor, with any employee of Laramie

County or its suppliers must be disclosed. Any such relationship that might be perceived or represented as a conflict should be disclosed. Failure to disclose any such relationship or reveal personal relationships with Laramie County employees may be cause for contract termination. Laramie County will decide if an actual or perceived conflict should result in bid disqualification. By submitting a response to this RFB, all respondents affirm that they have not given, nor intend to give, any time hereafter any economic opportunity, future employment, gift, loan, gratuity, special discount, tip, favor, or service to a Laramie County employee or representative in connection with the procurement.

Governmental Immunity

Laramie County does not waive its Governmental/Sovereign Immunity, as provided by any applicable law including W.S. 1-39-101 et seq., by issuing this RFB or by entering into any subsequent agreement. Further, Laramie County fully retains all immunities and defenses provided by law with regard to any action, whether in tort, contract or any other theory of law, based on this RFB or any subsequent agreement.

Indemnification

To the fullest extent permitted by law, the successful respondent agrees to indemnify and hold harmless Laramie County, its appointed officials, elected officials, employees and volunteers from any and all liability for injuries, damages, claims, penalties, actions, demands or expenses arising from or in connection with any work performed by or on behalf of respondent for Laramie County pursuant to any agreement with Laramie County.

Termination

The selection may be terminated (a) by either party at any time for failure of the other party to comply with the terms and conditions of the RFB or any subsequent agreement; (b) by either party, with thirty days' prior written notice to the other party; or (c) upon mutual written agreement by both parties.

Force Majeure

Neither the respondent nor Laramie County shall be liable to perform under this RFB or subsequent agreement if such failure arises out of causes beyond control, and without the fault or the negligence of said party. Such causes may include, but are not restricted to, Act of God or the public enemy, fires, floods, epidemics, quarantine restrictions, freight embargoes and unusually severe weather. In every case, however, a failure to perform must be beyond the control and without the fault or the negligence of said party.

The submission of a bid shall be considered acceptance to all the terms and conditions provided herein and in the various bid documents, unless specifically noted otherwise in the bid.

[REMAINDER OF PAGE LEFT INTENTIONALLY BLANK]

6.0 BID FORM (Attachment)

TO: John Poelma
13797 Prairie Center Circle
Cheyenne, WY 82009
(307) 633-4302

The undersigned hereby declares that [firm name] _____

_____ have carefully examined the specifications to furnish: **One (1) new Commercial Asphalt Paver** for which bids were advertised to be received **no later than 2:00 PM, MST, June 1, 2023** and further declare that [firm name]

_____ will furnish the said work according to specifications.

Proposed Cost Total Estimated Cost for Project: \$ _____

The above prices are all inclusive; County shall pay no other forms of compensation. The County reserves the right to add additional related services that were not known at the time of the publishing of this RFB to any resulting contract, upon negotiations with awarded contractors that is mutually agreeable.

Have you supplied the Submittal Requirements outlined above? _____ YES _____ NO

Laramie County reserves the right to reject any or all bids, to waive informalities, and to accept all or any part of any bid as they may deem to be in the best interest of the County.

I hereby certify that I have read and understand the requirements of this Request for Bids and, that I as the respondent, will comply with all requirements, and that I am duly authorized to execute this bid/offer document and any contract(s) and/or other transactions required by award of this RFB.

Company _____

By _____ (Print name)

Signature _____

Address _____

City _____ State _____ ZIP _____

Telephone _____ Fax _____

E-Mail Address: _____

DUNS# _____

6.0 BID FORM Attachment)

TO: John Poelma
13797 Prairie Center Circle
Cheyenne, WY 82009
(307) 633-4302

The undersigned hereby declares that [firm name] Wyoming Machinery Company

have carefully examined the specifications to furnish: **One (1) new Commercial Asphalt Paver** for which bids were advertised to be received no later than 2:00 PM, MST, June 1, 2023 and further declare that [firm name]

Wyoming Machinery Company will furnish the said work according to specifications.

Proposed Cost Total Estimated Cost for Project: \$ 266,660.00

The above prices are all inclusive; County shall pay no other forms of compensation. The County reserves the right to add additional related services that were not known at the time of the publishing of this RFB to any resulting contract, upon negotiations with awarded contractors that is mutually agreeable.

Have you supplied the Submittal Requirements outlined above? YES NO

Laramie County reserves the right to reject any or all bids, to waive informalities, and to accept all or any part of any bid as they may deem to be in the best interest of the County.

I hereby certify that I have read and understand the requirements of this Request for Bids and, that I as the respondent, will comply with all requirements, and that I am duly authorized to execute this bid/offer document and any contract(s) and/or other transactions required by award of this RFB.

Company Wyoming Machinery Company

By Jeff Baynard (Print name)

Signature Jeff Baynard

Address 7819 Hutchins Dr.

City Cheyenne State WY ZIP 82007

Telephone (307) 631-9066 Fax (307) 633-2525

E-Mail Address: JRBaynard@wyomingcat.com

DUNS# 048128227

REFERENCES

Trade References:

1.) Contact Name: Toby Hohnholt Phone Number: (307) 331-3514

Company: Town of Wheatland
Address: 600 9th St. City: Wheatland State: WY
Zip Code: 82201

2.) Contact Name: Andrew Boomgarden Phone Number: (307) 251-3436

Company: Grizzly Excavation & Construction
Address: 3441 Burd Rd. City: Casper State: WY
Zip Code: 82601

3.) Contact Name: Trent Richardson Phone Number: (308) 530-4198

Company: Simon Contractors
Address: 4819 South Industrial Rd City: Cheyenne State: WY
Zip Code: 82007

1.0 Purpose & Overview

Laramie County Public Works is soliciting competitive, sealed bids from qualified vendors to provide one (1) new Commercial Asphalt Paver.

2.0 Scope of Services

Specifications for Bid

Estimated date of delivery: April 2024

General

- Diesel engine (120 Horse Power min)
 - Meets specifications: Yes No **Standard HP for the Weiler P385C is 120hp.**
- Adjustable screed (8' – 15'8" preferred)
 - Meets specifications: Yes No **8' to 15'8" standard paving width screed.**
- Hopper capacity (8 tons min)
 - Meets specifications: Yes No **9-ton hopper capacity.**
- Heated screed
 - Meets specifications: Yes No **4 element electric heated screed w/ thermostatic control.**
- Vibratory screed (500 Vibrations Per Minute min)
 - Meets specifications: Yes No **2 x 2500 vpm**
- Generator (12kw min)
 - Meets specifications: Yes No **Hydraulically driven 12 kW generator.**
- 12" augers with reverse function
 - Meets specifications: Yes No **12" Auger diameter w/ reversing.**
- 19" truck clearance
 - Meets specifications: Yes No **19" truck clearance.**
- Spray down tank (5-gallon capacity min)
 - Meets specifications: Yes No **8-gal spray down system with 2 hoses/nozzles**
- Truck dump width 118" (inside)
 - Meets specifications: Yes No **118" Truck Dump Width Inside.**
- Lockable vandal covers
 - Meets specifications: Yes No **Lockable vandal covers and engine access doors.**

- Adjustable hopper sides
 - Meets specifications: Yes No **Cut-off doors standard.**
- Conveyor with reverse function (Heavy Duty chains and flights)
 - Meets specifications: Yes No **Highway class chains, conveyor and auger bearings provide long-term reliability.**
- Hydrostatic drive
 - Meets specifications: Yes No **3-Speed hydrostatic drive, 350 fpm transport speed.**
- Automatic track tensioning
 - Meets specifications: Yes No **Automatic track tensioning standard.**
- 3/8" thick screed plates (main and extension)
 - Meets specifications: Yes No **3/8" (9.5 mm) thick screed plates.**
- Sonic feed sensors
 - Meets specifications: Yes No **Sonic feed sensors standard.**
- Manual crown control (+3%)
 - Meets specifications: Yes No **Manual crown adjustment (+/-3%).**
- Rear walkways
 - Meets specifications: Yes No **Folding rear walkways standard.**
- Truck push rollers (hydraulically extended)
 - Meets specifications: Yes No **Hydraulically extendable push rollers.**
- LED strobe and work lighting
 - Meets specifications: Yes No **LED strobe and works lights standard.**
- Grade and slope controls
 - Meets specifications: Yes No **TOPCON P-32 Dual Grade w/ Slope Group.**
- Remote grease lines
 - Meets specifications: Yes No **Remote grease fittings.**
- Screed mounted control panels
 - Meets specifications: Yes No **Optioned with lower screed mounted panel control group.**

Safety & Other

- Paper copies of Service, Repair, and Parts Manuals (to be supplied upon delivery)
 - Meets specifications: Yes No
- One complete set of filters shall be provided
 - Meets specifications: Yes No



228390-01

May 12, 2023

LARAMIE COUNTY PUBLIC WORKS
13797 PRAIRIE CENTER CIRCLE
CHEYENNE, Wyoming 82009



Thank you for this opportunity to quote this Caterpillar product for your business needs. We are pleased to quote the following for your purchase consideration.

One (1) New Weiler Model P385C Paver with all standard equipment in addition to the additional specifications listed below:

STOCK NUMBER: SERIAL NUMBER: YEAR: 2024 SMU: NEW

Thank you for allowing us at Wyoming Machinery Company to serve your business needs. This quotation is valid for 30 days, after which time we reserve the right to re-quote. If there are any questions, please do not hesitate to contact me.

Sincerely,

Jeff Baynard
Machine Sales Representative
Wyoming Machinery Company
JRBaynard@wyomingcat.com
(307) 631-9066

POWERTRAIN:

Cat® C3.6 Tier 4F engine with 120 hp (74 kW)
3-Speed hydrostatic drive, 350 fpm (106 mpm) transport speed
Automatic track tensioning
90" (2,286 mm) track length with 68" (1,727 mm) of ground contact
14" (356 mm) performance, poly track pads
6 track rollers per side
140 mm track chain pitch
Hydraulically driven 12 kW generator

OPERATING ENVIRONMENT:

Dual operating stations
3 operating positions - high, mid and screed
Push button keypads
LCD display provides conditions and diagnostics
Pause mode enables return to same settings
Steering wheel standard, propel levers optional
Optional screed mounted control panels

MATERIAL DELIVERY:

9-ton (8.1 mt) hopper
Replaceable floor plates
Heavy-duty chains and flight bars
Narrow chain guards
12" (305 mm) Ni-hard augers
Adjustable push roller
Independent auger and conveyor controls
Cut-off doors
Independent hopper control

SCREED:

8' (2.44 m) to 15'8" (4.80 m) standard paving width
4 element electric heated screed w/ thermostatic control
3/8" (9.5 mm) thick screed plates
Grade and slope controls
Sonic feed sensors
Manual crown adjustment (+-3%)
Folding rear walkway
Adjustable end gates

SERVICE/MAINTENANCE:

8 gallon spray down system with 2 hoses/nozzles
Braided electrical harnesses and sealed connections
12-volt electric system with automotive-type fuses
Remote grease fittings
5 engine access doors
Lockable vandal covers and engine access doors

OPTIONAL EQUIPMENT:

Truck hitch
Hydraulically extendable push rollers
Additional operator seat
Walk way extensions
Propel levers
LED strobe light
Work lights
LED work lights
DC LED blade lights
Screed mounted control panels
Hand held remote
Auto grade and slope controls
Heated end gates
Electric screed extension height adjustment
Power hydraulic slope
Hydraulic power crown Cut-off shoes
12" (305 mm), 18" (457 mm), 24" (610 mm) berm attachment
Hydraulic integrated berm

MACHINE SPECIFICATIONS

P385C ASPHALT PAVER <i>Includes:</i> <i>Cat®3.6 Tier 4F/Stage V, 120 HP Engine</i> <i>140 mm Track Group w/ 14" Poly Pads</i> <i>Adjustable, Oscillating Push Rollers with Adjustable Scrapers</i> <i>Paver Pause Function, Grade and Slope Prep Group</i> <i>Spray Down w/ Separate Tank and 3 Spray Hoses</i> <i>Dual Operator's Stations w/ One Seat</i> <i>Steering Wheel Control Group</i> <i>LED Work Lights (9) and Strobe Light</i>	P385C-002	HYDRAULICALLY ADJUSTABLE PUSH ROLLER GROUP	P385C-013
SCREED W/ ELECTRIC THERMOSTATIC CONTROLLED HEAT <i>Manual Adjustable Extender Height and Manual Adjustable Slope</i> <i>Heated End Gates</i> <i>Sliding Walkway Extensions</i>	P385C-250	LOWER ADDITIONAL SCREED MOUNTED CONTROL PANEL GROUP	P385C-150
U.S. ENGLISH LANGUAGE AND DECAL GROUP	P385C-601	PANEL HYDRAULIC SLOPE GROUP	P385C-301
TOPCON P-32 DUAL GRADE W/ SLOPE GROUP	P385C-214	SCREED CUT-OFF SHOE GROUP	P385C-310
		FILTER KIT	

SELL PRICE
\$266,660.00

WARRANTY & COVERAGE: Caterpillar C3.6 has 2 years or 3000 hours coverage through Caterpillar.
Weiler Machine Warranty is 12 Months.

F.O.B./TERMS:
Cheyenne, WY
OPTIONS (Not Included in above Price):

Components	Ref No.	Qty	Sell
Other Components			
Trimble Roadworks 2D System	2023-68944	1	+\$19,835.00
Single Umbrella Group	P385C-060	1	\$230.00
Truck Hitch Group	P385C-011	1	\$6,725.00
Truck Hitch Prep Group	P385C-012	1	\$1,400.00
Additional Operator's Seat Group	P385C-100	1	\$980.00
Joystick Steering Control Group		1	\$0.00
Second Steering Indicator Group		1	\$179.00
Handheld Remote Group (Order 2 for Both Sides)	P385C-118	1	\$770.00
DC Blade Light Group (2 lights)	P385C-127	1	\$2,255.00
Electric Screed Extension Height Adjustment Group (requires P385C-150)	P385C-300	1	\$2,425.00
Hydraulic Power Crown Group (requires P385C-150)	P385C-303	1	\$4,035.00
1' Auger Extension Group	P385C-326	1	\$1,255.00
12" Integrated Hydraulic Berm Group w/Heated Endgates (requires P385C-150)	P385C-330	1	\$7,240.00
18" Integrated Hydraulic Berm Group w/Heated Endgates (requires P385C-150)	P385C-331	1	\$7,240.00
1' Bolt-On Extensions w/Heat Group (left and right)	P385C-333	1	\$6,365.00
Black Paint Color	P385C-951	1	\$4,290.00

P385C COMMERCIAL PAVER



BUILT FOR HIGH PRODUCTION.

Engineered and built to exceed the demands of commercial paving, the Weiler P385C incorporates proven designs with new innovations to provide performance, reliability and outstanding mat quality in a wide range of applications.



PROVEN SCREED.

The Weiler designed 3,700 lb (1678 kg) screed delivers outstanding mat quality and a wide paving range. The 8' (2.4m) front mount screed is hydraulically extendable to 15' 8" (4.80 m).

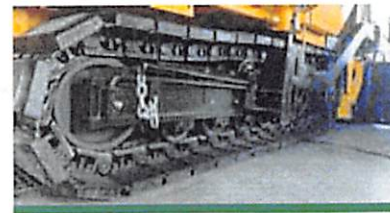

LARGEST UNDERCARRIAGE.

Best-in-class 90" (2286 mm) track length with 68" (1727 mm) of ground contact and 140 mm track chain pitch provides smooth ride and excellent flotation. Automatic track tensioning ensures performance and maximizes component life.



VISIBILITY AND CONTROL.

The P385C has three different operating positions allowing for optimal visibility while the adjustable, magnetic-resistance intelligent steering system allows for reliable control.

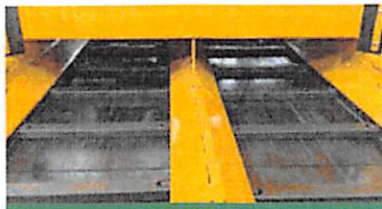

DURABLE COMPONENTS.

Highway class chains, conveyor and auger bearings provide long-term reliability. Remote grease lines located on the front of the counterweight provide easy daily maintenance.



FAST SERVICE.

Remote grease lines, spray down system with three coiled hoses and timer, five engine access doors and Caterpillar dealer service and support keep your machine up and running.



P385C SPECIFICATIONS

WEIGHT	22,000 lb	9979 kg
LENGTH	14' 8"	4470 mm
WIDTH	102"	2591 mm
HEIGHT	76"	1930 mm
TRUCK CLEARANCE	19"	482 mm
AUGER DIAMETER	12"	305 mm

SCREED WEIGHT	3,700 lb	1678 kg
MAIN PLATE WIDTH	16.5"	419 mm
EXTENSION PLATE WIDTH	9"	228 mm
SCREED HEAT	Electric - 4 elements	
VIBRATION	2 x 2500 vpm	
AUGER SPEED	150 rpm - variable	

ENGINE	Cat® C3.6 Tier 4F/Stage V	
PAVING SPEED	150 fpm	45 mpm
TRANSPORT SPEED	350 fpm	106 mpm
FUEL CAPACITY	40 gal	151 L
HYDRAULIC CAPACITY	30 gal	114 L
DEF CAPACITY	5 gal	18 L

POWERTRAIN

- Cat® C3.6 Tier 4F/Stage V engine with 120 hp (90 kW)
- 3-Speed hydrostatic drive, 350 fpm (106 mpm) transport speed
- Automatic track tensioning
- 90" (2,286 mm) track length with 68" (1,727 mm) of ground contact
- 14" (356 mm) performance, poly track pads
- 6 track rollers per side
- 140 mm track chain pitch
- Hydraulically driven 12 kW generator

OPERATING ENVIRONMENT

- Dual operating stations
- 3 operating positions - high, mid and screed
- Push button keypads
- LCD display provides conditions and diagnostics
- Pause mode enables return to same settings
- Steering wheel standard, propel levers optional
- Optional screed mounted control panels
- LED strobe and works lights

MATERIAL DELIVERY

- 9-ton (8.1 mt) hopper
- Replaceable floor plates
- Heavy-duty chains and flight bars
- Narrow chain guards
- 12" (305 mm) Ni-hard augers
- Adjustable push roller
- Variable speed and reversible augers and conveyors
- Cut-off doors
- Hydraulic tow points

SALES AND SERVICE

Sold and serviced through Caterpillar dealers worldwide.

SCREED

- 8' (2.44 m) to 15' 8" (4.80 m) standard paving width (17' 8" max)
- 4 element electric heated screed w/ thermostatic control
- 3/8" (9.5 mm) thick screed plates
- Grade and slope controls
- Sonic feed sensors
- Manual crown adjustment (+-3%)
- Folding rear walkways
- Spring loaded end gates w/ heated shoes

SERVICE/MAINTENANCE

- 8 gal (30 L) spray down system with 3 hoses/nozzles
- Braided electrical harnesses and sealed connections
- 12-volt electric system with automotive-type fuses
- Remote grease fittings
- 5 engine access doors
- Lockable vandal covers and engine access doors

OPTIONAL EQUIPMENT

- Truck hitch
- Hydraulically extendable push rollers
- Umbrella
- Additional operator seat
- Second Steering Indicator Group
- Propel levers
- DC LED blade lights
- Screed mounted control panels
- Hand held remote
- Auto grade and slope controls
- Electric screed extension height adjustment
- Power hydraulic slope
- Hydraulic power crown
- Cut-off shoes
- 12" (305 mm), 18" (457 mm), 24" (610 mm) bolt-on berm attachment
- 12" and 18" hydraulic integrated berm
- Auger & tunnel extensions
- 1' heated bolt-on screed extensions

WARRANTY

12 months standard. Extended warranty available.

Advanced Screed Control for Asphalt Pavers

P-32/P-32+

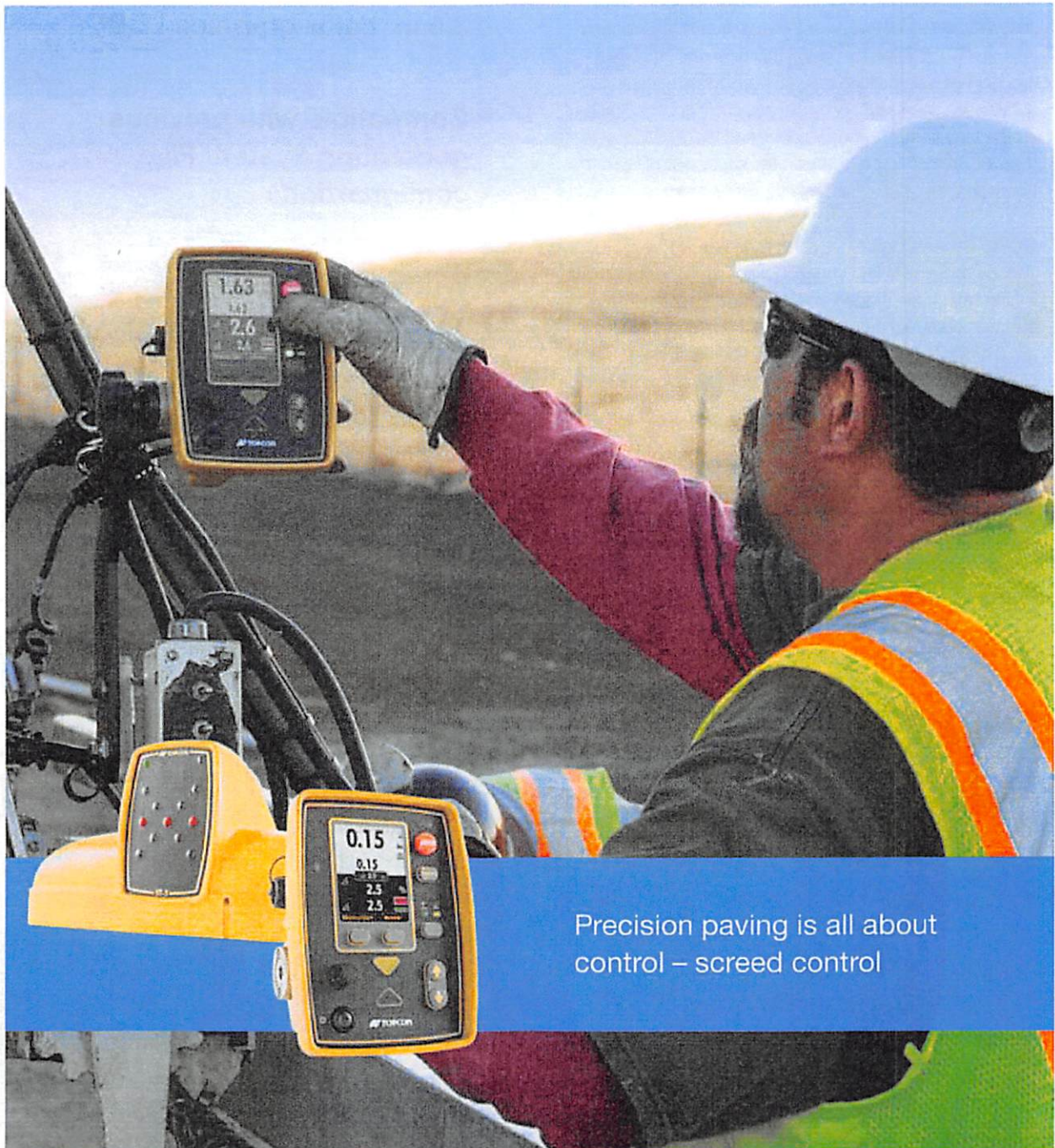

Next Generation of Advanced Screed Control

P-32/P-32+

Topcon continues its long tradition of innovation with the P-32/P-32+ for asphalt pavers. For decades, the Topcon System Five solution for paving has been the industry's premier non-contacting screed control system. Featuring durable and time-tested components, such as Sonic Trackers, cross slope sensors, control boxes and the Trackerjack laser receiver, Topcon has introduced the successor of System Five with the P-32/P-32+ asphalt paver system.

GC-35 Control Box

Topcon has an exciting control box for its 2D asphalt paver system which are rugged and waterproof with an IP67 environmental rating and can be sold on new pavers or as an upgrade to the System Five 9256 control boxes. The GC-35 includes a new mounting bracket, cables and a heavy duty double shelled carrying case.

The control boxes feature superior design, a faster processor and better on-screen options. The side-mounted cable connectors – versus bottom mounted – help keep cables away from moving parts on the paver. The increased processor speed and improved on-screen options make the system run faster and easier.

3.5 in. color graphics LCD

Compatible with previous generation System Five configurations

Waterproof and IP67 rated

Rugged cable design with strong strain relief

Operate both sides of the screed from one control box



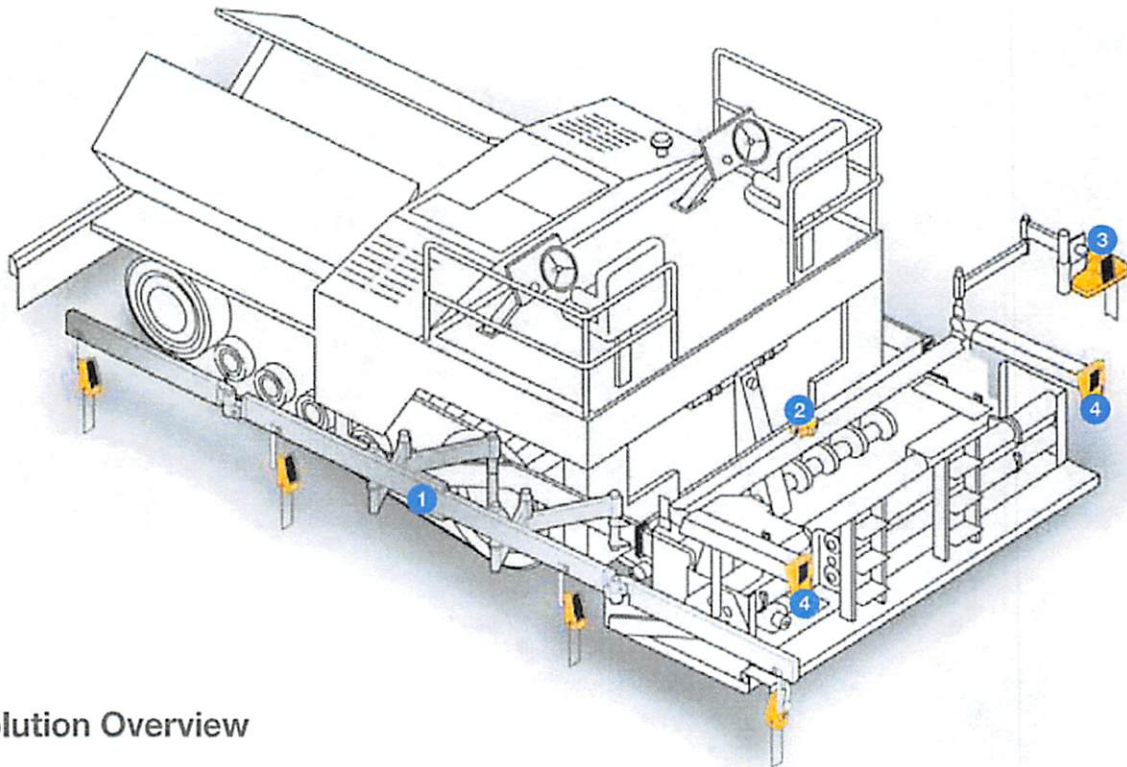

Solution Overview

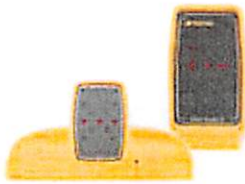

1

Sonic Averaging Ski with Sonic Trackers

4x Sonic Tracker II's or
4x ST-3 Sonic Trackers



2

Slope Sensor



3

ST-3 Sonic Tracker



4

GC-35 Control Box

Sonic Averaging System

The Topcon Sonic Averaging System has been the paving industry's first choice as a non-contacting replacement to the conventional mechanical ski. The Sonic Averaging System is comprised of an aluminum beam with four Sonic Trackers which continuously measure the elevation over the surface, automatically averaging and adjusting the low point cylinder. The Sonic Averaging System is convenient, maneuverable and produces a great finished surface.

GC-35 Paver System Control Box

With a 3.5 in. color graphics LCD, the display is easy to see day or night. View elevation and slope values for both sides of the screed from either side. Calibrating the system is much easier with on-screen menu choices and is faster than using the previous generation of control boxes.





GC-35 Control Box

- Waterproof and IP67 rated
- Backward compatible with System Five paver systems
- Designed with side mount connectors
- Faster processor and easy performance menu access
- Operate both sides of the screed from one control box



ST-3 Sonic Tracker

- Waterproof and IP67 rated
- Sideway offset indication on stringline
- Flat detection range on stringline
- Smoother and faster response
- Twice as fast detection speed



Topcon Delta Log

- Exclusive anti-slosh ceramic technology
- Completely sealed internal electronics
- Rugged cast housing
- Insensitive to vibration
- Improved accuracy over extended temperature range



Trackerjack

- 360° gapless receiving
- Motorized receiver gets on-grade and "locks-on" to keep it there
- Bright grade indication LED's display continuous grade information
- Compatible with all Topcon lasers



Specifications subject to change without notice.
 © 2021 Topcon Corporation. All rights reserved.
 7010-2130 D 11/21

www.topconpositioning.com/p-32

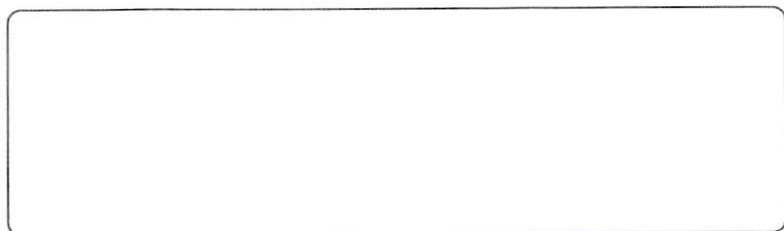



227253-01

May 22, 2023

LARAMIE COUNTY PUBLIC WORKS
13797 PRAIRIE CENTER CIRCLE
CHEYENNE, Wyoming 82009

Thank you for this opportunity to quote this Weiler product for your business needs.

Wyoming Machinery Company is an authorized dealer to sell and service Weiler Paving and Forestry equipment.

Weiler equipment is engineered with innovative features to increase productivity while reducing operating costs. To maximize those benefits, Weiler factory support works together with the world-class Caterpillar dealer network to ensure your success through:

- Engineered innovation in our products providing maximum productivity while reducing operating costs
- Dedicated Weiler Product Specialists in the field for operational training and support
- Factory trained dealer technicians to provide timely and accurate service for minimal down time
- Weiler Service Specialists working closely with dealer techs to troubleshoot and repair your equipment
- Dealer inventoried parts to keep your machine up and running

Wyoming Machinery Company in Cheyenne works with Weiler to offer service and support on both Caterpillar and Weiler equipment. Below are some benefits that set us apart from the competition.

PARTS:

Our parts department is a 15,000 square foot warehouse housing approximately 10,000-line items. We receive two trucks a day from our Denver Depot. If orders are placed before 10:00 A.M we can receive parts from Denver the same day. We also have a truck that runs at night between Cheyenne and Casper. This helps with expediting component delivery to the CRC, SOS sample delivery, as well as parts filling from Casper. Past fill rate has been between 95% and 96% within 36 hours of the time of order, which means a quicker turnaround time for our customers. With current worldwide supply chain issues, current fill rates cannot be determined accurately.

Our parts department is also equipped with a custom hose building shop where we can build almost any type and size of hose, including non-CAT machines and hoses. All CAT machines are equipped with a metal tag on each hydraulic hose with the part number of those. This gives the customer the ability to call with a part number so we can build the hose before we come out. This leaves the system less time to be exposed to contamination and increases up-time of the machine. We have 3 hose press machines, including the ability to repair reclaimable hose ends. After the hose is crimped it is measured in 4 spots to ensure a proper crimp to increase safety of the hose. Each hose is then cleaned before it is finished, and the ends of the hoses are capped for delivery to eliminate contaminants entering the hose during storage or transport.

Parts Dept Hours of Operation: Mon. – Fri.: 7am – 6pm, Sat.: 8am – 12pm

Parts Call Out Hours: 12pm-6pm on Saturday and 6am to 6pm on Sunday

SERVICE:

Currently we have 11 full-time Field Service technicians, including a mobile lube technician, and a forklift technician. We also employ 7 full-time Heavy Equipment Shop technicians. The Cheyenne facility is primarily responsible for Laramie, Goshen, Platte, and Albany counties. Field service availability varies, but is usually within 48 hours. Emergencies can typically be attended to within the same day. In shop availability varies as well, but as with field service, emergencies can typically be attended to in a shorter timeframe.

Current Service Hours of Operation: Mon. – Fri.: 7am – 4pm : On call field service available.

Thank you for allowing us at Wyoming Machinery Company to serve your business needs. If there are any questions, please do not hesitate to contact me.

Sincerely,

Jeff Baynard
Machine Sales Representative
Wyoming Machinery Company
JRBaynard@wyomingcat.com
(307) 631-9066

WEILER WARRANTY
-Exclusive Limited Warranty-

Caterpillar C3.6 has 2 years or 3000 hours coverage through Caterpillar.

The manufacturer warrants each new WEILER PRODUCT to be free of defects in workmanship and material at the time of shipment to first end-user. The warranty period is 12 months.

- A. If a defect is found, and the authorized dealer is notified during the 12 month warranty period, the manufacturer will repair or replace any part or component on the unit that fails to conform to the warranty.
- B. The manufacturer has the right to repair any part or component prior to replacement.
- C. All new replacement parts will carry a six (6) month warranty. Remanufactured parts will carry a ninety (90) day warranty.
- D. ENGINES, TIRES, BATTERIES and ATTACHMENTS are normally warranted by their manufacturers and may have different warranty than that of the manufacturer.

NO WARRANTY OF ANY KIND SHALL BE MADE WITH RESPECT TO:

- A. Any defects or damage caused by misuse, misapplication, negligence accident or failure to maintain or use the product in accordance with current operating instructions.
- B. Any product that has been used with an attachment or in an application where excessive workload or stress causes failure of the part or component.
- C. Failure to conduct normal maintenance and operating service to include but not limited to providing lubricants, coolant, fuel, inspections and regular tune-ups.
- D. Unauthorized alterations, modifications and or replacements parts and components not manufactured by the manufacturer.

THE MANUFACTURER IS NOT RESPONSIBLE FOR THE FOLLOWING:

- A. Charges for travel time, mileage or overtime.
- B. Airfreight charges for parts shipped to point of service.
- C. Transportation charges to and from point of service.
- D. Consumable parts such as cutting edges, filters and items expected to receive normal wear and tear.
- E. Liability or damages of any type due to lost profits or expenses to acquire replacement products

EXCEPT AS SPECIFICALLY STATED ABOVE, THE MANUFACTURER MAKES NO WARRANTY OR REPRESENTATION, EXPRESS OR IMPLIED, INCLUDING, WITHOUT LIMITATION, ANY WARRANTY OF MERCHANTABILITY OR FITNESS FOR A PARTICULAR PURPOSE. THE WARRANTY SET FORTH ABOVE AND THE OBLIGATIONS AND LIABILITIES OF THE MANUFACTURER THEREUNDER REPRESENT CUSTOMER'S SOLE AND EXCLUSIVE REMEDIES AND ARE EXPRESSLY MADE IN LIEU OF ANY AND ALL OTHER REMEDIES, WARRANTIES, GUARANTIES OR LIABILITIES. THERE ARE NO WARRANTIES WHICH EXTEND BEYOND THE DESCRIPTION ON THE FACE HEREOF. IN NO EVENT SHALL THE MANUFACTURER'S LIABILITY HEREUNDER EXCEED THE PURCHASE PRICE FOR THE PRODUCTS, NOR SHALL THE MANUFACTURER BE LIABLE FOR ANY SPECIAL INDIRECT, INCIDENTAL OR CONSEQUENTIAL DAMAGES.

Customer Acceptance:

Signed _____

Print _____

Title _____

Date _____

WEILER P385C WARRANTY OPTIONS MATRIX

Weiler P385C		Machine Only	Engine	Both
24 Month or 2000 Hour Powertrain	P385B-805	\$2,590	N/A	\$2,590
24 Month or 2000 Hour Powertrain + Hyd	P385B-806	\$5,770	N/A	\$5,770
24 Month or 2000 Hour Powertrain + Hyd +Elec	P385B-814	\$6,940	N/A	\$6,940
36 Month or 3000 Hour Powertrain	P385B-800	\$3,530	\$775	\$4,305
36 Month or 3000 Hour Powertrain + Hyd	P385B-801	\$8,120	\$775	\$8,895
36 Month or 3000 Hour Powertrain + Hyd +Elec	P385B-809	\$9,295	\$775	\$10,070
48 Month or 4000 Hour Powertrain	P385B-802	\$4,120	\$1,475	\$5,595
48 Month or 4000 Hour Powertrain + Hyd	P385B-803	\$9,295	\$1,475	\$10,770
48 Month or 4000 Hour Powertrain + Hyd +Elec	P385B-804	\$10,470	\$1,475	\$11,945
60 Month or 5000 Hour Powertrain	P385B-808	\$9,765	\$2,590	\$12,355
60 Month or 5000 Hour Powertrain + Hyd	P385B-807	\$11,295	\$2,590	\$13,885
60 Month or 5000 Hour Powertrain + Hyd +Elec	P385B-811	\$13,650	\$2,590	\$16,240

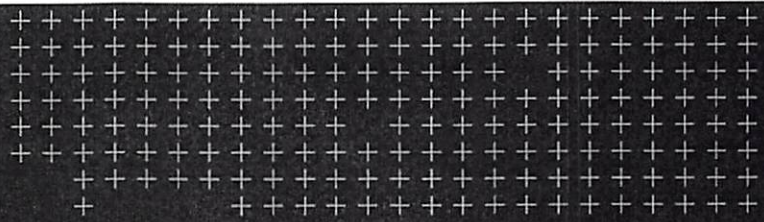

Trimble Roadworks

Paving Control Platform for Asphalt Pavers

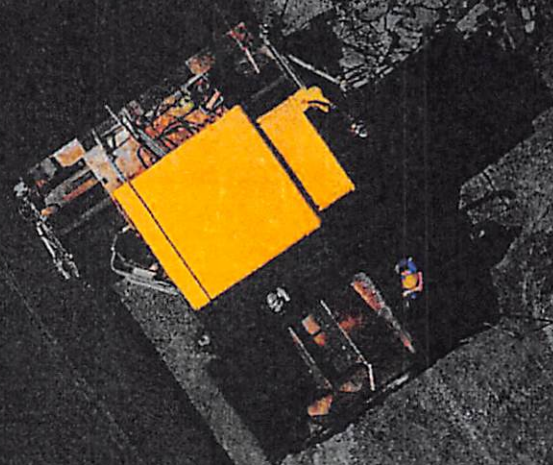

INTUITIVE SOFTWARE, RUGGED HARDWARE

The Trimble Roadworks Software runs on the 10-inch (25.4 cm) Trimble TD520 display for 3D applications, or the 7-inch (17.8 cm) Trimble TD510 display with tactile keypads for 2D applications. Colorful graphics, natural interactions and gestures, and self-discovery features make Trimble Roadworks intuitive and easy to learn.

Trimble Roadworks features a large display and an easy-to-understand layout for controlling cross slope and material thickness. Configurable views allow you to control and monitor the left and right side of the screed with just one operator, and make it easier to see the right perspective for maximum productivity. With the Android operating system, users can also download other applications that provide the operator with additional useful tools.

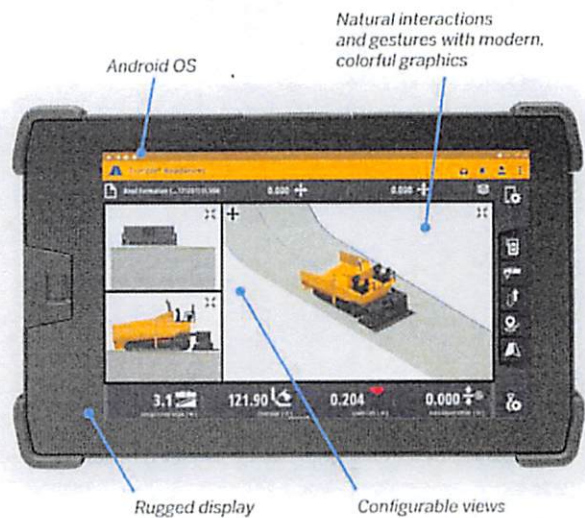

PRODUCTIVE AND PRECISE PAVING

- ▶ Achieve smoothness and accuracy up to the finished surface
- ▶ Minimize the use of expensive material by paving within a tighter tolerance and getting closer to the minimal asphalt thickness specification early in the process
- ▶ Improved sensor mobility to easily swap sensors based on application, such as cross-slope to joint matching configurations
- ▶ Monitor the measured and target values of the cross slope and mat thickness simultaneously
- ▶ Rugged and durable components for tough construction conditions, rated to protect against dust and water
- ▶ Reduce labor costs by controlling the screed with one operator
- ▶ Increase efficiency by eliminating the need to pick up the mechanical averaging beam when going over hot asphalt, storm drains or other obstructions
- ▶ In 2D applications, contractors can easily change sensor values and operate the system in the field with the combined touch-screen display and tactile keypads
- ▶ In 3D applications, eliminate any complications involving stringlines: human error, costly setup, maneuvering hazards, etc.



The Trimble Roadworks 2D display features tactile keypads for use in the field

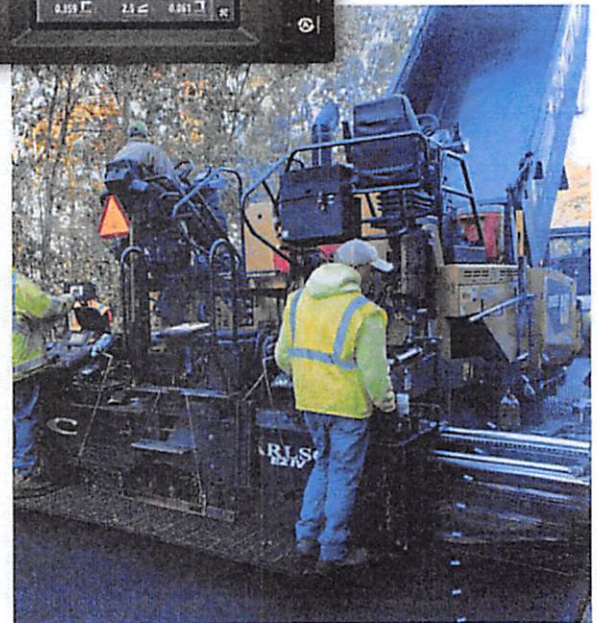

OFFICE TO FIELD CONNECTIVITY

Reduce waste and overruns with efficient communication and data transfer with Trimble WorksManager—mobile-friendly software that easily manages data and technology assets across jobsites.

With the Trimble SNM941 Connected Site® Gateway, transfer 3D designs from the office to the machine wirelessly and automatically so that the operator is always using the latest design. Productivity data collected from the machine can automatically sync back to the office.



Trimble WorksManager Software

Trimble Roadworks: Asphalt Paver Configuration Options

2D System

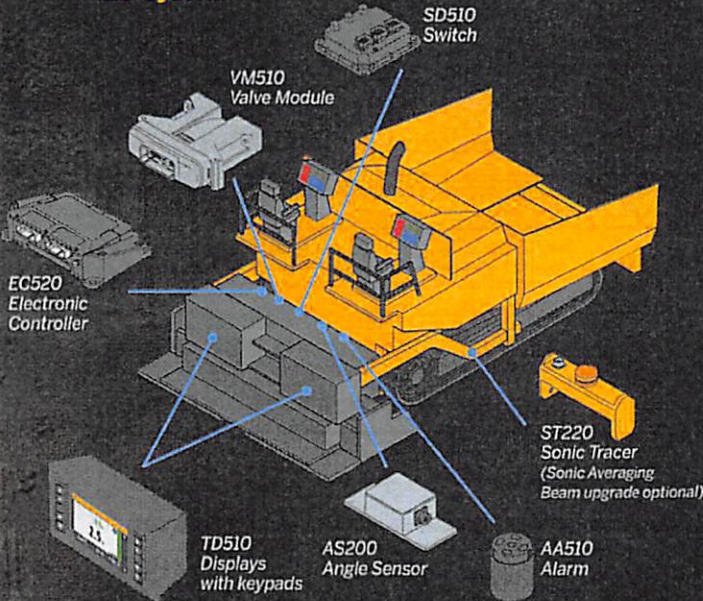

3D System

Install the Trimble Roadworks 3D system over many different paver 2D systems.

Single / Dual MT900 Machine Target with mast
(Dual not available on all asphalt paver configurations)

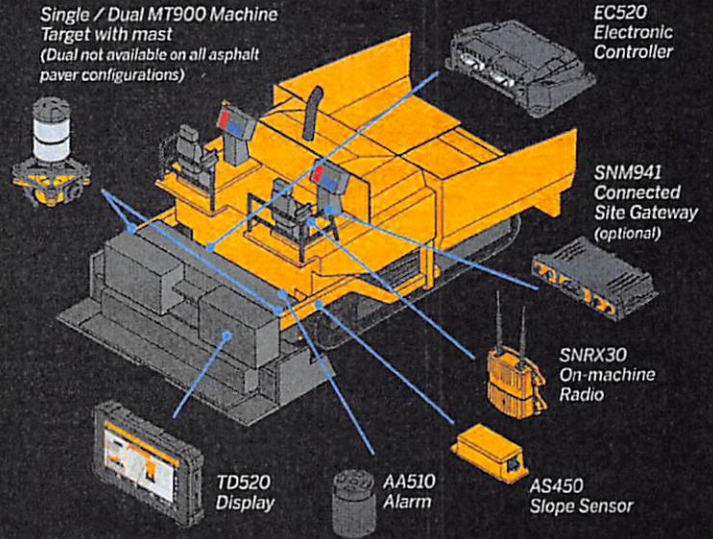

The Trimble Roadworks 2D system can reference off a surface, cross-slope or stringline, making it an excellent, lower cost option for roads that have been graded or milled using Trimble 3D paving control systems.

Slope Sensor Reference

The Trimble Roadworks 2D system can use the Trimble AS200 Angle Sensor to reference the desired cross-slope of the road. Designed specifically for asphalt pavers, the sensor rarely needs calibration to pave cross slopes accurately and consistently.



Surface Reference

Follow surfaces with contact-free accuracy. ST220 Sonic Tracers average out uneven reference surfaces such as stones, grates and shovels for better joint matching off previously laid asphalt layers and curbs, and a smoother, more accurate mat.

Trimble Civil Construction

10368 Westmoor Drive
Westminster, Colorado 80021 USA
construction_news@trimble.com

heavyindustry.trimble.com/roadworks

© 2021-2022, Trimble Inc. All rights reserved. Trimble and the Globe & Triangle are trademarks of Trimble Inc., registered in the United States and other countries. FN 022682-4295B (10/22)

Transforming the way the world works.



REQUEST FOR BIDS
Laramie County Public Works
One (1) new Commercial Asphalt Paver
Closing Date: June 1, 2023

Purpose of Request for Bids (RFB)

Laramie County is soliciting competitive bids for qualified vendors who can provide one (1) new Commercial Asphalt Paver for Laramie County Public Works. This project is being funded with Federal ARPA funds (ALN # 21.027) and selected vendor will be required to be registered in sam.gov.

Table of Contents

1.0	PURPOSE & OVERVIEW	2
2.0	SCOPE OF SERVICES	2
3.0	GENERAL TERMS & CONDITIONS	5
3.1	RFB CLOSING DATE.....	5
3.2	DELIVERY OF BIDS.....	5
3.3	PRE-BID INFORMATION.....	5
3.4	PUBLIC RFB OPENING.....	5
3.5	BID FORM.....	5
3.6	QUESTIONS CONCERNING RFB.....	6
3.7	CLARIFICATION AND ADDENDA.....	6
3.8	AWARD.....	6
3.9	CONTRACT.....	7
3.10	DISCLOSURE OF RFB CONTENT.....	7
3.11	RESPONDENT'S RESPONSIBILITY.....	7
3.12	PAYMENT TERMS.....	7
3.13	MINOR IRREGULARITIES.....	8
3.14	DEVIATIONS.....	8
3.15	SELECTION CRITERIA.....	8
3.16	TERMINATION / CANCELLATION OF CONTRACT.....	8
3.17	INCURRED EXPENSES.....	9
3.18	PRESENTATIONS BY RESPONDENTS	9
3.19	MINIMUM SPECIFICATIONS.....	9
3.20	RESPONDENT'S PERSONNEL.....	9
3.21	BID ACCEPTANCE/REJECTION.....	10
4.0	4.0 SUBMITTAL REQUIREMENTS	10
5.0	5.0 DISCLOSURES	10
6.0	BID FORM	13

Warranty and Training

TRAINING AND DIAGNOSTICS:

With delivery of Commercial Asphalt Paver, a qualified representative shall instruct County Operators and Mechanics in the proper operation, servicing, lubrication, adjustments, and preventative maintenance of the machine(s).

A complete set of printed service, parts, operator, and repair manuals and diagnostic software shall be supplied with the Commercial Asphalt Paver (if applicable).

WARRANTY PROGRAM AND SERVICE

Vendor will provide, in letter form only, the type of warranty supplied on quoted Commercial Asphalt Paver. The letter shall include the type of service provided, guarantee of parts, and cost of service during warranty period. The vendor may also provide any other material which they feel gives their machine an advantage on service and warranty. Please state any extended warranties and their associated cost in the warranty period.

The ability of the bidder to provide superior warranty and service may be used to determine a successful bidder.

Printed specifications on machine bid shall be presented. All above specifications filled in must be legible. With delivery of machine(s) and components, Manufacturer's Statement of Origin shall be supplied.

Additional Notes:

- A. The respondent shall provide the following information for each proposed system:
 1. A complete bid including all related costs for providing the equipment, supplies and installation as outlined above.
 2. Delivery of all equipment, supplies, and installation.
 3. Enter into a written contract for work with Laramie County.
 4. Contractor shall comply with all applicable Federal and State statutes and regulations as well as local ordinances.
- B. The person or persons provided by the respondent to complete work shall be fully qualified to provide said services.
- C. All work provided by the respondent shall be in conformance with local, state, and Federal rules and regulations.
- D. All equipment shall be responsive to the needs of the County, shall be performed in accordance with County programs, policies, and procedures, and shall utilize appropriate methods and techniques.

- E. All records, including digital information, video tapes and audio tapes, related to the contract services performed for the County shall be subject to the Wyoming Public Records Laws and shall be maintained and made available in accordance with those laws and public records policies and procedures of the County. Records shall be made available to the County without question upon request of the County, in accordance with the requirements of law. Citizen requests for such records shall be processed through the County. All records, including all types of electronic records, related to the contract and services performed there under shall be the property of the County at the end of the contract, or at the end of the County's fiscal year, or upon demand of the County, whichever occurs first. The County shall specify the minimum records to be maintained by the respondent. The respondent may maintain additional records at its discretion.

3.0 General Terms & Conditions

3.1 RFB Closing Date

Bids must be received by the Laramie County Public Works Department (LCPW) at 13797 Prairie Center Circle, Cheyenne, Wyoming 82009 no later than **2:00 PM, MST, on June 1, 2023**. Bids received after this time will not be considered. Please note for bid delivery purposes, the hours of operation for LCPW are Monday through Thursday, 6:00 AM to 4:30 PM, MST.

3.2 Delivery of Bids

All bids shall be sealed and delivered or mailed to the address of Laramie County Public Works (faxes and emails will not be accepted).

3.3 Pre-bid Information

No specific pre-bid meeting will be held. Each respondent shall contact John Poelma 307-633-4690 or john.poelma@laramiecountywy.gov to discuss the bid with the County, if needed.

3.4 Public RFB Opening

Only the names of the vendors submitting bids will be read aloud at the RFB opening. The bids will be available for inspection during normal business hours in the Laramie County Public Works Department within three (3) working days of the closing date, by appointment. Bid opening will occur on June 1, 2023, at 2:15 PM at the Laramie County Public Works office. A complete tabulation of bids will be available after it is completed.

Individuals covered by the Americans with Disabilities Act of 1990 in need of accommodations to attend public RFB openings or meetings should contact the Public Works Department in Cheyenne at (307) 633-4690 at least five (5) days prior to the date.

3.5 Bid Form

- A. See Submittal Requirements for complete details.

- B. Each respondent shall submit THREE (3) complete sets of the bid form, one marked "ORIGINAL" and TWO (2) marked "COPY". The bid shall be submitted on an exact copy of the attached bid form.
- C. The bid form must be signed by an official authorized to legally bind the respondent to all RFB provisions contained herein.
- D. Terms and conditions differing from those in this RFB may be cause for disqualification of the bid.

3.6 Questions Concerning RFB

Questions concerning any portion of this RFB should be directed in writing to John Poelma, Public Works Department, named below, who shall be the official point of contact for this RFB. Mark cover page or envelope(s) "**Commercial Asphalt Paver.**"

Submit questions to:

John Poelma
Assistant Director
Public Works
(307) 633-4690

john.poelma@laramiecountywy.gov

3.7 Clarification and Addenda

It is incumbent upon each respondent to carefully examine all specifications, terms, and conditions contained herein. Any inquiries, suggestions, or requests concerning interpretation, clarification or additional information shall be made in writing, (facsimile transmissions acceptable) through the Assistant Director named above. The County will not be responsible for any oral representation(s) given by any employee, representative or others. The issuance of a written addendum is the only official method by which interpretation, clarification or additional information can be given.

If it becomes necessary to revise or amend any part of this RFB, notice may be obtained by accessing the Laramie County web site. Respondents in their bid must acknowledge receipts of amendments. **Each respondent should ensure that they have received all addenda and amendments to this RFB before submitting their bid. Please check the Laramie County web site at <http://www.laramiecountywy.gov> for any addenda.**

3.8 Award

The County reserves the right to award the contract to the respondent(s) that the County deems to offer the best overall bid(s). The County is therefore not bound to accept a bid on the basis of lowest price. In addition, the County at its sole discretion, reserves the right to cancel this RFB, to modify the quantities of product we purchase, to reject any and all bids, to waive any and all informalities and/or irregularities, or to re-advertise with either the identical or revised specifications, if it is deemed to be in the best interest of the County to do so. The County also

reserves the right to make multiple awards, based on experience and qualifications if it is deemed to be in the County's best interest.

3.9 Contract

The contents of this RFB and all provisions of the successful bid deemed pertinent by the County may be incorporated into a contract and become legally binding. A separate contract document will be issued.

The County Commissioners are the sole Contracting Officer for Laramie County, Wyoming, and only he/she or his/her designee is authorized to make changes to any contract. The County shall be responsible for only those orders placed by the County on an authorized signed Purchase Order or Price Agreement. The County shall not be responsible for any order, change, substitution or any other discrepancy from the Purchase Order or Price Agreement. If there is any question about the authenticity of a Purchase Order, Price Agreement or change order, the respondent should promptly contact the Public Works Department at (307) 633-4690.

3.10 Disclosure of RFB Content

All material submitted becomes the property of the County and may be returned only at the County's option. The County has the right to use any or all ideas presented in any reply to this RFB. Selection or rejection of any bid does not affect this right.

3.11 Respondent's Responsibility

A respondent, by submitting a bid represents that:

- A. The respondent has read and understands the RFB in its entirety that and the bid is made in accordance therewith, and
- B. The respondent possesses the capabilities, resources, and personnel necessary to provide efficient and successful service to the County, and;
- C. Before submitting a bid, each respondent shall make all investigations and examinations necessary to ascertain site and/or local conditions and requirements affecting the full performance of the contract and to verify any representations made by Laramie County upon which the respondent will rely. If the respondent receives an award because of its bid submission, failure to have made such investigations and examinations will in no way relieve the respondent from its obligations to comply in every detail with all provisions and requirements of the contract, nor will a plea of ignorance of such conditions and requirements be accepted as a basis for any claim by the respondent for additional compensation or relief.

3.12 Payment Terms

The County will remit full payment on all undisputed invoices within forty-five (45) days from receipt by the appropriate person(s) (to be designated at time of contract) of the invoice(s) or receipt of all products or services ordered.

3.13 Minor Irregularities

The County reserves the right to waive minor irregularities in bids, providing such action is in the best interest of the County. Minor irregularities are defined as those that have no adverse effect on the County's best interests and will not affect the outcome of the selection process by giving the respondent an advantage or benefit not enjoyed by other respondents.

3.14 Deviations

All bids must clearly and with specific detail, note all deviations to the exact requirements imposed upon the respondent by the General Terms & Conditions. Such deviations must be stated upon the Bid Form; otherwise, Laramie County will consider the subject bids as being made in strict compliance with said General Terms & Conditions to respondents; the respondent being held therefore accountable and responsible. Respondents are hereby advised that Laramie County will only consider bids that meet the exact requirements imposed by the General Terms & Conditions; except, however, said bids may not be subject to such rejection where, at the sole discretion of Laramie County, the stated deviation is considered to be equal or better than the imposed requirement and where said deviation does not destroy the competitive character of the RFB process by affecting the amount of the bid such that an advantage or benefit is gained to the detriment of the other respondents.

3.15 Selection Criteria

Each bid shall be evaluated using the following criteria:

1. Proper submittal of ALL documentation as required by this bid
2. Overall scope and quality of the proposed project
3. Meeting or exceeding the requirements of the RFB
4. Quality and compatibility of the work proposed
5. Ability to accomplish project in a timely manner
6. The benefits to Laramie County as it pertains to:
 - a. Related experience in the areas covered in the RFB
 - b. Past record of performance on contracts with government agencies and private industry with respect to such factors as control of costs, quality of work and ability to meet schedules
 - c. Experience, ability, and overall quality of past and current projects

3.16 Termination / Cancellation of Contract

The County reserves the right to cancel the contract without cause with a minimum thirty (30) days written notice. Termination or cancellation of the contract will not relieve the respondent of any obligations for any deliverables entered into prior to the termination of the contract (i.e., reports, materials, statements of accounts, etc., required and not received). Termination or

cancellation of the contract will not relieve the respondent of any obligations or liabilities resulting from any acts committed by the respondent prior to the termination of the contract.

3.17 Incurred Expenses

This RFB does not commit Laramie County to award a contract. Nor shall Laramie County be responsible for any cost or expense which may be incurred by the respondent in preparing and submitting the bid called for in this RFB, or any cost or expense incurred by the respondent prior to the execution of a contract agreement.

3.18 Presentations by Respondents

Laramie County, at its sole discretion, may ask individual respondents to make oral presentations and/or demonstrations without charge to the County.

The County reserves the right to require any respondent to demonstrate to the satisfaction of the County that the respondent has the fiscal and managerial abilities to properly furnish the services proposed and required to fulfill the contract. The demonstration must satisfy the County and the County shall be the sole judge of compliance.

Respondents are cautioned not to assume that presentations will be required and should include all pertinent and required information in their original bid package.

3.19 Minimum Specifications

The specifications listed in the Scope of Service are the minimum required performance specifications for this RFB. They are not intended to limit competition nor specify any particular respondent, but to ensure that the County receives quality services.

3.20 Respondent's Personnel

The respondent shall be responsible for ensuring that its employees, agents and subcontractors comply with all applicable laws and regulations and meet all federal, state and local requirements related to their employment and position. The respondent certifies that it does not and will not during the performance of the contract employ illegal alien workers or otherwise violate the provisions of the federal Immigration Reform and Control Act of 1986, as amended. During the performance of the contract, the respondent agrees to the following:

The respondent shall not discriminate against any employee or applicant for employment because of race, religion, color, sex, age, handicap or national origin, except when such condition is a bona fide occupational qualification reasonably necessary for the normal operations of the respondent.

The respondent agrees to post in conspicuous places, visible to employees and applicants for employment, notices setting forth the provisions of this nondiscrimination clause.

The respondent, in all solicitations or advertisements for employees placed by or on behalf of the respondent, shall state that such respondent is an Equal Opportunity Employer.

3.21 Bid Acceptance/Rejection

The County reserves the right to accept or reject any or all bids received as a result of this RFB, or to negotiate separately with competing respondents, and to waive any informalities, defects, or irregularities in any bid, or to accept that bid or bids, which in the judgment of the proper officials, is in the best interest of the County.

4.0 Submittal Requirements

Bids shall include all the information solicited in this RFB, and any additional data that the respondent deems pertinent to the understanding and evaluating of the bid. Bids shall be organized, and sections tabbed in the following order. The respondent should not withhold any information from the written response in anticipation of presenting the information orally or in a demonstration, since oral presentations or demonstrations may not be solicited. All bids shall include at minimum:

Tab 1 – Respondent’s Profile

A brief profile of the firm, including the firm’s overall qualifications to provide services necessary to fulfill all requirements outlined in the project Scope of Work.

Tab 2 - Completed Bid Form (use attached form)

Tab 3 – References

List at least three (3) recent references where the equivalent project(s) have been conducted within the past five years.

Tab 4 – Other Information

Include any additional information you believe will assist the County in the selection process of qualified respondents. Please be succinct.

5.0 Disclosures

The laws of Wyoming require that the contents of all bids shall be placed in the public domain and be open to inspection by interested parties. Trade secrets or proprietary information that are recognized as such and are protected by law may be withheld if clearly identified as such in the bid. The entire bid cannot be designated as proprietary or a trade secret. If a request is received to examine portions designated as proprietary or a trade secret, Laramie County will notify the vendor to permit the vendor to defend the proprietary nature of the information.

If a respondent discovers any ambiguity, conflict, discrepancy, exclusionary specifications, omission, or other error in this document, the respondent shall immediately notify the issuing office. If the respondent is awarded a contract, then such respondent will not be entitled to additional compensation, relief, or time by reason of the error or its later correction.

The successful respondent will be expected to enter into a contract with Laramie County upon terms acceptable to the County. Respondent will be required to be registered in Sam.gov to receive federal ARPA funding as a contractor/vendor to this RFB.

Following the award of the contract, responses to this bid are subject to release as public information unless specific parts of the response can be shown to be exempt from the laws of the State of Wyoming. Respondents are advised to consult with their legal counsel regarding disclosure issues and take the appropriate precautions to safeguard trade secrets or any other proprietary information. Laramie County assumes no obligation or responsibility for asserting legal arguments on behalf of potential respondents.

If a respondent believes that parts of a bid are confidential then the respondent must so specify. The respondent must mark in bold red letters the term “**CONFIDENTIAL**” on that part of the response, which the respondent believes to be confidential. The respondent must submit in writing specific detailed reasons, including any relevant legal authority, stating why the respondent believes the material to be confidential. Vague and general claims as to confidentiality will not be accepted. Laramie County will be the sole judge as to whether a claim is general and/or vague in nature. All parts of bids, which are not marked as confidential, will be automatically considered public information after the contract is awarded. The successful bid may be considered public information even though parts are marked confidential.

Bids must be signed by a person authorized to commit the respondent to provide the services requested in this RFB. Submission of a signed bid will be interpreted to mean the respondent has agreed to all terms and conditions set forth in all of the sheets which make up this RFB.

Laramie County accepts no obligations for the costs incurred in responding to this RFB in anticipation of being awarded a contract. Laramie County reserves the right to reject any and all submitted bids. It is understood that all bids become the property of Laramie County and will be available for public inspection. No obligation is made by retention of these bids, nor is Laramie County committed to awarding a contract as a result of this RFB.

Each respondent must disclose any existing or potential conflict of interest relative to the performance of the requirements of this bid. Examples of potential conflicts may include an existing business or personal relationship between the respondent, its principal or any affiliate or subcontractor, with Laramie County or any other entity or person involved in any way in the project that is the subject of this RFB. Similarly, any personal or business relationship between the respondent, the principals, or an affiliate or subcontractor, with any employee of Laramie

County or its suppliers must be disclosed. Any such relationship that might be perceived or represented as a conflict should be disclosed. Failure to disclose any such relationship or reveal personal relationships with Laramie County employees may be cause for contract termination. Laramie County will decide if an actual or perceived conflict should result in bid disqualification. By submitting a response to this RFB, all respondents affirm that they have not given, nor intend to give, any time hereafter any economic opportunity, future employment, gift, loan, gratuity, special discount, tip, favor, or service to a Laramie County employee or representative in connection with the procurement.

Governmental Immunity

Laramie County does not waive its Governmental/Sovereign Immunity, as provided by any applicable law including W.S. 1-39-101 et seq., by issuing this RFB or by entering into any subsequent agreement. Further, Laramie County fully retains all immunities and defenses provided by law with regard to any action, whether in tort, contract or any other theory of law, based on this RFB or any subsequent agreement.

Indemnification

To the fullest extent permitted by law, the successful respondent agrees to indemnify and hold harmless Laramie County, its appointed officials, elected officials, employees and volunteers from any and all liability for injuries, damages, claims, penalties, actions, demands or expenses arising from or in connection with any work performed by or on behalf of respondent for Laramie County pursuant to any agreement with Laramie County.

Termination

The selection may be terminated (a) by either party at any time for failure of the other party to comply with the terms and conditions of the RFB or any subsequent agreement; (b) by either party, with thirty days' prior written notice to the other party; or (c) upon mutual written agreement by both parties.

Force Majeure

Neither the respondent nor Laramie County shall be liable to perform under this RFB or subsequent agreement if such failure arises out of causes beyond control, and without the fault or the negligence of said party. Such causes may include, but are not restricted to, Act of God or the public enemy, fires, floods, epidemics, quarantine restrictions, freight embargoes and unusually severe weather. In every case, however, a failure to perform must be beyond the control and without the fault or the negligence of said party.

The submission of a bid shall be considered acceptance to all the terms and conditions provided herein and in the various bid documents, unless specifically noted otherwise in the bid.

[REMAINDER OF PAGE LEFT INTENTIONALLY BLANK]